

LG HVAC Solution

Air Cooled Inverter Scroll Chiller

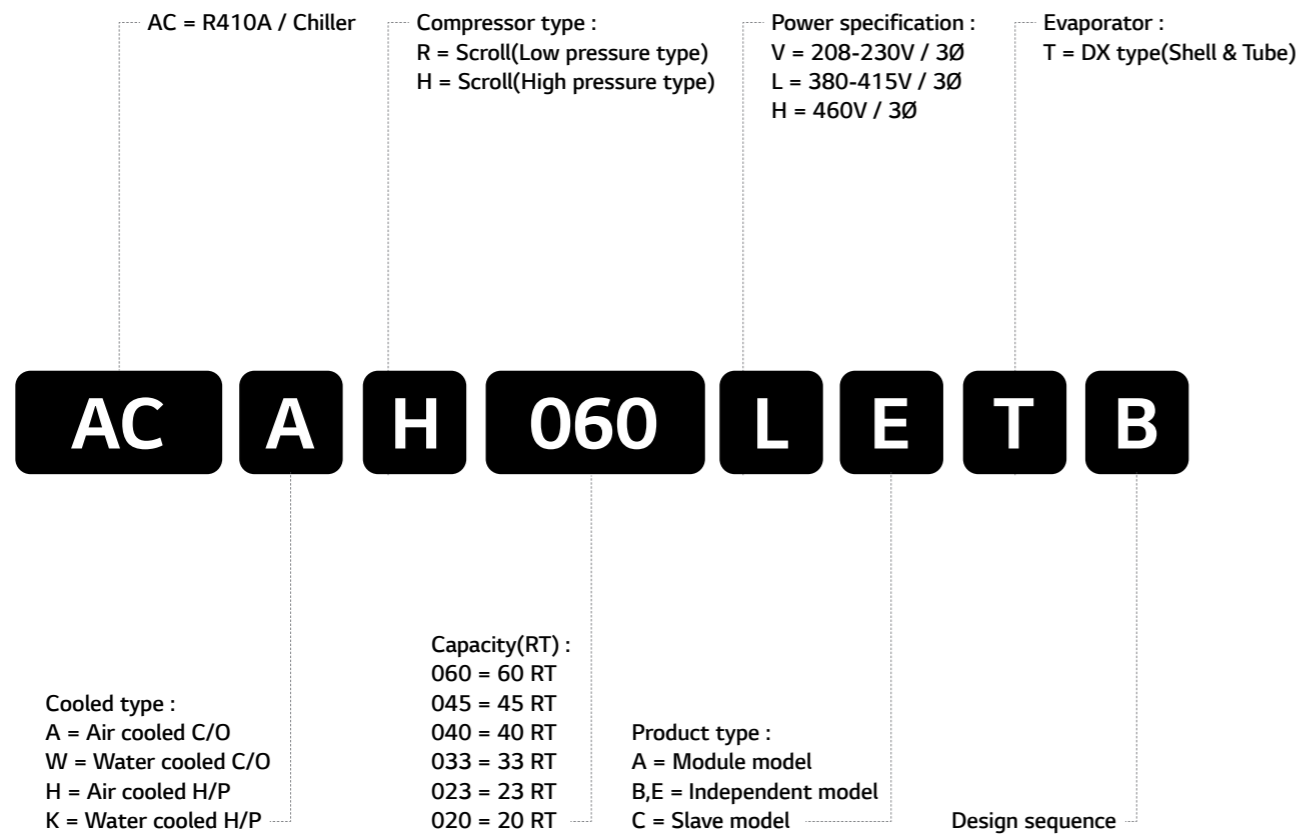

- The copyright of this catalog belongs to LG Electronics, and unauthorized reprinting or redistribution without prior approval may result in sanctions under relevant laws.
- For continual product development, LG reserves the right to change specifications or designs without notice.
- This catalog uses recyclable paper.
- 2022 LG Electronics. Printed in Korea. Oct. 2022



Contents

- 02 Nomenclature
- 03 Line up & Introduction
- 04 Features
- 06 Specification
- 12 Electric characteristics
- 13 Outline dimension
- 18 Foundation
- 20 Piping diagram
- 25 Wiring diagram
- 35 Installation of chiller
- 41 Guide specification

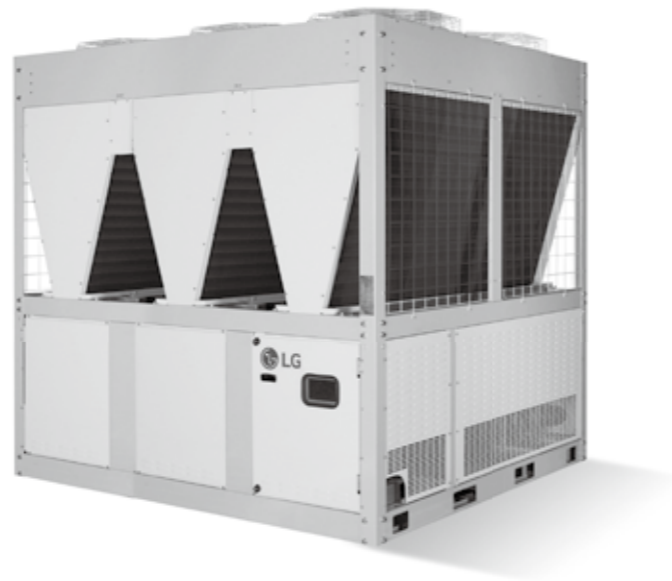

Line up

| Model | | 10 | 20 | 30 | 40 | 50 | 60 | 70 |
|--------------------------------------|--|----|------|------------------|------|------|------|----|
| Cooling Only 220V 380V 460V | | | 18RT | | | 55RT | | |
| | | | 18RT | | | | 63RT | |
| | | | 18RT | | | | 63RT | |
| Heat Pump 380-415V | | | 18RT | Cooling Capacity | 42RT | | | |
| | | | 20RT | Heating Capacity | 46RT | | | |

* @T1 Condition

* Up to 5 units per 1 HMI can be controlled.

LG Air cooled water chillers are complete, self-contained automatic refrigerating units that include the latest in engineering components arranged to provide a compact and efficient unit. Each unit is completely assembled; factory wired, evacuated, charged, tested and comes complete and ready for installation. Each unit consists of multiple air-cooled condensers with integral sub-cooler sections, two or more accessible hermetically scroll compressors, high efficiency evaporator, and electronic expansion valves.



- High-performance compressor manufactured by LG to ensure that the chiller is economical and durable with low vibration and low noise.
- Highly integrated motherboard is adopted and hence the function is strong and reliable.
- Advanced control algorithm is adopted to control chiller in advance and hence avoid frequent stoppage protection of chiller.
- We have set complete safety protection function in order to make chiller safely and reliably run.
- The linkage control and remote monitoring function of peripheral equipment ensure that the chiller can run safely and the operation and monitoring are convenient.
- The selection of excellent raw materials and fittings is the key to guaranteeing chiller quality.

Excellent reliability and Powerful operation

The cutting-edge design of Air-cooled scroll chiller accomplishes high performance and reliability for industrial and commercial

market.

LG Air-cooled scroll compressors are precisely machined from solid compound metal bar using profound cutting process. Tolerance is maintained within a few microns just like one-tenth hair thickness. Robust components with highly skilled assembling process help the compressor last for a long time. LG condenser production technology is already well-known to worldwide air conditioning manufacturing industries because of its leading technologies.

World class high efficiency

The evaporator uses internally grooved tubes having helical angle which enhanced the refrigerant side heat transfer performance. The V-shape of condenser allows the largest heat transfer surface area for the same footprint, resulting in largest heat transfer performance when the configuration is optimally designed.

The LG V-shape condenser coil was designed using numerical and experimental analysis, having optimum air flow path to

optimize heat rejection performance.

Also, the enhanced condenser fin geometry allows the optimum heat transfer performance at small air side pressure drop, and this reduces the fan-motor power consumption. The fin is pre-coated to prevent corrosion at normal conditions and epoxy coated fin condenser which is sustainable in harsh conditions, is also available as option.

Low noise and Low vibration

The unit was designed with a compact structure and robust assembly. The condenser fan is completed with high-efficiency wing style axial fan and direct driven motor for low sound level. The unit configures compressor sound insulation box(Optional), which makes LG chillers silent and stable.

Installation, start-up

- Small operating footprint fit most retrofit applications.
- Factory testing for high reliability.
- Factory-installed and tested controls help to reduce start up time and minimized extra cost.
- Display temperatures and pressure for each component spot.

Compressor specification

- Hermetically sealed DC Scroll compressor.
- Variable Speed Drive(VSD)
- The VSD optimized for part-load conditions.
- A refrigerant dispersing device is set internally to the compressor for motor cooling.

Factory testing/Unit performance testing

LG air-cooled scroll chillers are given a complete functional test at the factory. LG computer-based testing programs completely check the components including sensors, wiring, electronics and microprocessor control functions.

LG promotes factory performance tests for air-cooled chillers to show that we stand behind the products which are designed and build up.

The benefits of a performance test include verification of performance, prevention of operational problems, and assurance of a smooth start-up. Each compressor is run and tested to verify capacity and efficiency.

Structural strength analysis

Structure is designed to ensure stiffness for various disturbances by steps of structure modeling, meshing, excitation and evaluation.

Structural strength evaluation simulation

Aerodynamic analysis

Condenser part is appropriately designed by aerodynamic analysis like inlet and outlet uniform airflow design and dead zone reduction design.

Heat circulation evaluation simulation

Refrigerant R410A

System designed with Eco-friendly refrigerant R410A which does not harm the ozone layer & protects the environment. The HCFC(R22, R123) series cannot produce any more from 2020 according to the Montreal Protocol for protection of ozone layer.

Black fin(Heat exchanger)

Heat Exchanger of outdoor unit is the core part that contributes to consistent cooling performance, yet is most vulnerable to corrosion. LG's exclusive black fin is highly corrosion resistant, designed to perform in corrosive environments such as coastal area.

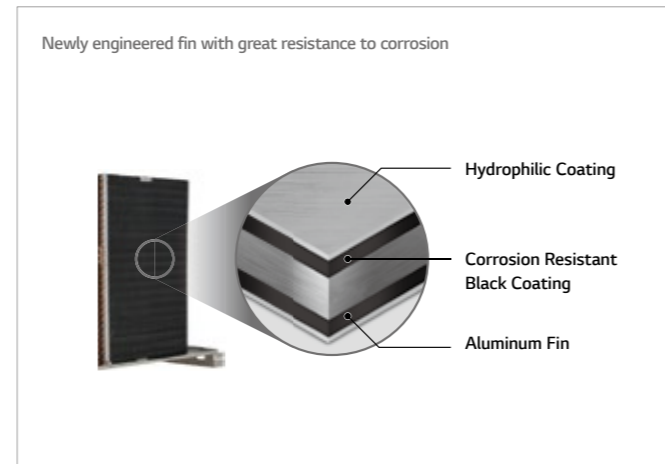

Black fin(Heat exchanger)

Black coating

The black coating is heavy anti-corrosion treatment applied to industrial equipment in the ocean. This special coating protects heat exchanger from high salinity, humidity and pollution

Salt water spray test

Heat exchanger with black fin passed 3,000 hour salt water spray test, while conventional heat exchanger started to corrode after 1,000 hours.

Selection guide

The product information required in various requirements is written in detail from performance data.

If you need a product for special system application or product with the condition outside this catalogue, please get

consultation from nearby sales office or specialty store.

Selection procedure

1. Check usage condition

Before selecting the model, the following usage conditions must be decided.

- Chilled water in/out temperature and outdoor temperature
- Chilled water flow amount(Flow amount can be calculated if you know the freezing load and chilled water in/out temperature.)

2. Selecting candidate model

Required rated capability is selected through load calculation, and you can select the corresponding model by looking at specification & performance data table.

When you select the candidate model, do not select a model with less volume than the required rated capability, but select a model with the same or bigger volume.

3. Performance adjustment for fouling

The data in this technical data manual is based on chilled water fouling coefficient of 0.000018 m²°C/W at sea level. If altitude or fouling coefficient is different, you have to apply appropriate adjustment coefficient form the following table to calculate data for the operation condition.

| Altitude | Water in/out temperature difference(°C) | Fouling coefficient | | | |
|----------------|---|------------------------------|-------------------|------------------------------|-------------------|
| | | 0.000018 m ² °C/W | | 0.000054 m ² °C/W | |
| | | Cooling capability | Power consumption | Cooling capability | Power consumption |
| Sea level (0m) | 4 | 0.991 | 0.998 | 0.979 | 0.996 |
| | 5 | 1.000 | 1.000 | 0.990 | 0.998 |
| | 6 | 1.010 | 1.002 | 1.001 | 1.000 |
| | 7 | 1.020 | 1.005 | 1.010 | 1.003 |
| 500 m | 4 | 0.988 | 1.004 | 0.979 | 1.002 |
| | 5 | 0.998 | 1.006 | 0.988 | 1.004 |
| | 6 | 1.008 | 1.008 | 0.998 | 1.006 |
| | 7 | 1.017 | 1.010 | 1.008 | 1.008 |
| 1,000 m | 4 | 0.985 | 1.011 | 0.977 | 1.008 |
| | 5 | 0.995 | 1.013 | 0.985 | 1.010 |
| | 6 | 1.005 | 1.015 | 0.995 | 1.012 |
| | 7 | 1.014 | 1.017 | 1.005 | 1.014 |
| 1,500 m | 4 | 0.982 | 1.018 | 0.974 | 1.016 |
| | 5 | 0.992 | 1.020 | 0.983 | 1.018 |
| | 6 | 1.002 | 1.022 | 0.993 | 1.020 |
| | 7 | 1.011 | 1.025 | 1.003 | 1.023 |
| | 8 | 1.020 | 1.027 | 1.011 | 1.025 |

4. Performance adjustment after adding freeze and burst prevention solution.

If cooling operation is performed in Winter, or if water inside

the cycle is not removed in the resting phase, you have to add freeze and burst prevention solution to protect from freeze and burst.

Freezer characteristics change by adding freeze and burst prevention solution, so it should be adjusted.

Refer to the following table for the adjustment coefficient after adding freeze and burst prevention solution.

| Antifreeze Type | Item | Antifreeze % by wt | | | | |
|------------------|---------------|--------------------|-------|-------|-------|-------|
| | | 10 % | 20 % | 30 % | 40 % | 50 % |
| Methanol | Cooling | 0.998 | 0.997 | 0.995 | 0.993 | 0.992 |
| | Heating | 0.995 | 0.990 | 0.985 | 0.979 | 0.974 |
| | Pressure Drop | 1.023 | 1.057 | 1.091 | 1.122 | 1.160 |
| Ethylene glycol | Cooling | 0.996 | 0.991 | 0.987 | 0.983 | 0.979 |
| | Heating | 0.993 | 0.985 | 0.977 | 0.969 | 0.961 |
| | Pressure Drop | 1.024 | 1.068 | 1.124 | 1.188 | 1.263 |
| Propylene glycol | Cooling | 0.993 | 0.987 | 0.980 | 0.974 | 0.968 |
| | Heating | 0.966 | 0.973 | 0.960 | 0.948 | 0.935 |
| | Pressure Drop | 1.040 | 1.098 | 1.174 | 1.273 | 1.405 |

5. Finalizing the model

As a result of verifying product performance and power consumption considering various adjustment coefficients for the candidate models, if there is no problem, you can finalize it as the final model.

If there is a problem, review again from the candidate model selection stage.

208-230V

| Inverter Scroll Chiller | | Model | ACAH020VETB | ACAH033VETB | ACAH040VETB | ACAH050VETB | ACAH060VETB |
|--------------------------------|---|--------------------|-------------------|-------------------|-------------------|-------------------|-------------------|
| | | | C/O | C/O | C/O | C/O | C/O |
| Power | Phase, Lines, V | 3, 3, 208-230 | | | | | |
| Capacity | kW | 65 | 114 | 130 | 171 | 195 | |
| | RT | 18.5 | 32.4 | 37 | 48.6 | 55.4 | |
| Input Power | kW | 21.7 | 36.8 | 43.3 | 55.2 | 65.0 | |
| Efficiency | W/W | 3.00 | 3.10 | 3.00 | 3.10 | 3.00 | |
| IPLV | W/W | 5.0 | 5.1 | 5.0 | 5.1 | 5.0 | |
| Sound Pressure | dB(A) | 64 | 66 | 67 | 68 | 69 | |
| Compressor | Type | - | Inverter Scroll | | | | |
| | No. of Compressor | EA | 2 | 4 | 4 | 6 | 6 |
| | Oil Type | - | PVE | | | | |
| | Oil charge | cc | 1,400 x 2 | 1,400 x 4 | 1,400 x 4 | 1,400 x 6 | 1,400 x 6 |
| Refrigerant | Type | - | R410A | | | | |
| | Amount of Charged | kg | 6.5 x 2 | 6.5 x 4 | 6.5 x 4 | 6.5 x 6 | 6.5 x 6 |
| Evaporator | Type | - | Shell & Tube | | | | |
| | Pressure drop | kPa | 38.8 | 29.6 | 38.8 | 29.6 | 38.8 |
| | Operating maximum pressure(Refrigerant / Water) | kg/cm ² | 42/10 | | | | |
| | Water Flow Rate(Standard) | LPM | 186 | 327 | 372 | 491 | 558 |
| | Inlet/Outlet diameter(Water pipe) | mm | 50A/50A | 65A/65A | 65A/65A | 65A/65A | 65A/65A |
| Fan motor | Type | - | BLDC | | | | |
| | No. of Fan | EA | 2 | 4 | 4 | 6 | 6 |
| | No. of Vanes(per fan) | EA | 6 | | | | |
| | Air Flow Rate | CMM | 246 x 2 @1,000rpm | 246 x 4 @1,000rpm | 246 x 4 @1,000rpm | 246 x 6 @1,000rpm | 246 x 6 @1,000rpm |
| | Motor power | W | 900 x 2 | 900 x 4 | 900 x 4 | 900 x 6 | 900 x 6 |
| Expansion unit | - | EEV | | | | | |
| Weight | kg | 560 | 1,034 | 1,034 | 1,522 | 1,522 | |
| Dimension | W | mm | 765 | 1,528 | 1,528 | 2,291 | 2,291 |
| | H | mm | 2,200 | | | | |
| | D | mm | 2,154 | | | | |
| Footprint | m ² /RT | 0.089 | 0.102 | 0.089 | 0.101 | 0.089 | |
| Protection Devices | High/Low Pressure | - | 0 | | | | |
| | Anti Frost | - | 0 | | | | |
| Remote Control | - | Modbus | | | | | |
| Outlet Temperature | °C | 4-20 | | | | | |
| Ambient Temperature | °C | -15-48 | | | | | |
| Guaranteed Load Capacity Range | - | 20 % - 100 % | | | | | |

Note:
 1. Due to our policy of innovation some specifications may be changed without prior notification.
 2. Capacities and Inputs are based on the following conditions.
 Cooling : Outdoor air temp. 35°C, Water inlet temp. 12°C, Water Outlet temp. 7°C
 3. The AHRI Certified® mark indicates LG Electronics participation in the AHRI Certification program. For verification of individual certified products, go to www.ahridirectory.org.
 4. The ACAH***VETB / ACAH***HETB models are certified by AHRI to AHRI Standard 550/590.

380V

| Inverter Scroll Chiller | | Model | ACAH020LETB | ACAH023LETB | ACAH033LETB | ACAH040LETB |
|--------------------------------|---|--------------------|-------------------|-------------------|-------------------|-------------------|
| | | | C/O | C/O | C/O | C/O |
| Power | Phase, Lines, V | 3, 4, 380-415 | | | | |
| Capacity | kW | 65 | 74 | 114 | 130 | |
| | RT | 18.5 | 21.0 | 32.4 | 37.0 | |
| Input Power | kW | 21.5 | 28.5 | 36.2 | 43.0 | |
| Efficiency | W/W | 3.02 | 2.60 | 3.15 | 3.02 | |
| IPLV | W/W | 5.3 | 5.1 | 5.4 | 5.3 | |
| Sound Pressure | dB(A) | 64 | 66 | 66 | 67 | |
| Compressor | Type | - | Inverter Scroll | | | |
| | No. of Compressor | EA | 2 | 2 | 4 | 4 |
| | Oil Type | - | PVE | | | |
| | Oil charge | cc | 1,400 x 2 | 1,400 x 2 | 1,400 x 4 | 1,400 x 4 |
| Refrigerant | Type | - | R410A | | | |
| | Amount of Charged | kg | 6.5 x 2 | 6.5 x 2 | 6.5 x 4 | 6.5 x 4 |
| Evaporator | Type | - | Shell & Tube | | | |
| | Pressure drop | kPa | 38.8 | 49.2 | 29.6 | 38.8 |
| | Operating maximum pressure(Refrigerant / Water) | kg/cm ² | 42/10 | | | |
| | Water Flow Rate(Standard) | LPM | 186 | 211 | 327 | 372 |
| | Inlet/Outlet diameter(Water pipe) | mm | 50A/50A | 50A/50A | 65A/65A | 65A/65A |
| Fan motor | Type | - | BLDC | | | |
| | No. of Fan | EA | 2 | 2 | 4 | 4 |
| | No. of Vanes(per fan) | EA | 6 | | | |
| | Air Flow Rate | CMM | 246 x 2 @1,000rpm | 246 x 2 @1,000rpm | 246 x 4 @1,000rpm | 246 x 4 @1,000rpm |
| | Motor power | W | 900 x 2 | 900 x 2 | 900 x 4 | 900 x 4 |
| Expansion unit | - | EEV | | | | |
| Weight | kg | 560 | 560 | 1,034 | 1,034 | |
| Dimension | W | mm | 765 | 765 | 1,528 | 1,528 |
| | H | mm | 2,200 | | | |
| | D | mm | 2,154 | | | |
| Footprint | m ² /RT | 0.089 | 0.078 | 0.102 | 0.089 | |
| Protection Devices | High/Low Pressure | - | 0 | | | |
| | Anti Frost | - | 0 | | | |
| Remote Control | - | Modbus | | | | |
| Outlet Temperature | °C | 4-20 | | | | |
| Ambient Temperature | °C | -15-48 | | | | |
| Guaranteed Load Capacity Range | - | 20 % - 100 % | | | | |

Note:
 1. Due to our policy of innovation some specifications may be changed without prior notification.
 2. Capacities and Inputs are based on the following conditions.
 Cooling : Outdoor air temp. 35°C, Water inlet temp. 12°C, Water Outlet temp. 7°C
 3. The AHRI Certified® mark indicates LG Electronics participation in the AHRI Certification program. For verification of individual certified products, go to www.ahridirectory.org.
 4. The ACAH***VETB / ACAH***HETB models are certified by AHRI to AHRI Standard 550/590.

380V

| Inverter Scroll Chiller | Model | ACAHO45LETB | ACAHO50LETB | ACAHO60LETB | ACAHO67LETB | |
|--------------------------------|---|--------------------|-------------------|-------------------|-------------------|-------------------|
| | | C/O | C/O | C/O | C/O | |
| Power | Phase, Lines, V | 3, 4, 380-415 | | | | |
| Capacity | kW | 148 | 171 | 195 | 222 | |
| | RT | 42.1 | 48.6 | 55.4 | 63.1 | |
| Input Power | kW | 56.9 | 54.3 | 64.6 | 85.4 | |
| Efficiency | W/W | 2.60 | 3.15 | 3.02 | 2.60 | |
| IPLV | W/W | 5.1 | 5.4 | 5.3 | 5.1 | |
| Sound Pressure | dB(A) | 69 | 68 | 69 | 71 | |
| Compressor | Type | Inverter Scroll | | | | |
| | No. of Compressor | EA | 4 | 6 | 6 | 6 |
| | Oil Type | PVE | | | | |
| | Oil charge | cc | 1,400 x 4 | 1,400 x 6 | 1,400 x 6 | 1,400 x 6 |
| Refrigerant | Type | R410A | | | | |
| | Amount of Charged | kg | 6.5 x 4 | 6.5 x 6 | 6.5 x 6 | 6.5 x 6 |
| Evaporator | Type | Shell & Tube | | | | |
| | Pressure drop | kPa | 49.2 | 29.6 | 38.8 | 49.2 |
| | Operating maximum pressure(Refrigerant / Water) | kg/cm ² | 42/10 | | | |
| | Water Flow Rate(Standard) | LPM | 422 | 491 | 558 | 633 |
| | Inlet/Outlet diameter(Water pipe) | mm | 65A/65A | | | |
| Fan motor | Type | BLDC | | | | |
| | No. of Fan | EA | 4 | 6 | 6 | 6 |
| | No. of Vanes(per fan) | EA | 6 | | | |
| | Air Flow Rate | CMM | 246 x 4 @1,000rpm | 246 x 6 @1,000rpm | 246 x 6 @1,000rpm | 246 x 6 @1,000rpm |
| | Motor power | W | 900 x 4 | 900 x 6 | 900 x 6 | 900 x 6 |
| Expansion unit | - | EEV | | | | |
| Weight | kg | 1,034 | 1,522 | 1,522 | 1,522 | |
| Dimension | W | mm | 1,528 | 2,291 | 2,291 | 2,291 |
| | H | mm | 2,200 | | | |
| | D | mm | 2,154 | | | |
| Footprint | m ² /RT | 0.078 | 0.101 | 0.089 | 0.078 | |
| Protection Devices | High/Low Pressure | - | 0 | | | |
| | Anti Frost | - | 0 | | | |
| Remote Control | - | Modbus | | | | |
| Outlet Temperature | °C | 4~20 | | | | |
| Ambient Temperature | °C | -15~48 | | | | |
| Guaranteed Load Capacity Range | - | 20 % ~ 100 % | | | | |

Note:
 1. Due to our policy of innovation some specifications may be changed without prior notification.
 2. Capacities and Inputs are based on the following conditions.
 Cooling : Outdoor air temp. 35°C, Water inlet temp. 12°C, Water Outlet temp. 7°C
 3. The AHRI Certified® mark indicates LG Electronics participation in the AHRI Certification program. For verification of individual certified products, go to www.ahridirectory.org.
 4. The ACAH***VETB / ACAH***HETB models are certified by AHRI to AHRI Standard 550/590.

460V

| Inverter Scroll Chiller | Model | ACAHO20HETB | ACAHO23HETB | ACAHO33HETB | ACAHO40HETB | |
|--------------------------------|---|--------------------|-------------------|-------------------|-------------------|-------------------|
| | | C/O | C/O | C/O | C/O | |
| Power | Phase, Lines, V | 3, 3, 460 | | | | |
| Capacity | kW | 65 | 74 | 114 | 130 | |
| | RT | 18.5 | 21.0 | 32.4 | 37.0 | |
| Input Power | kW | 21.5 | 28.5 | 36.2 | 43.0 | |
| Efficiency | W/W | 3.02 | 2.60 | 3.15 | 3.02 | |
| IPLV | W/W | 5.3 | 5.1 | 5.4 | 5.3 | |
| Sound Pressure | dB(A) | 64 | 66 | 66 | 67 | |
| Compressor | Type | Inverter Scroll | | | | |
| | No. of Compressor | EA | 2 | 2 | 4 | 4 |
| | Oil Type | PVE | | | | |
| | Oil charge | cc | 1,400 x 2 | 1,400 x 2 | 1,400 x 4 | 1,400 x 4 |
| Refrigerant | Type | R410A | | | | |
| | Amount of Charged | kg | 6.5 x 2 | 6.5 x 2 | 6.5 x 4 | 6.5 x 4 |
| Evaporator | Type | Shell & Tube | | | | |
| | Pressure drop | kPa | 38.8 | 49.2 | 29.6 | 38.8 |
| | Operating maximum pressure(Refrigerant / Water) | kg/cm ² | 42/10 | | | |
| | Water Flow Rate(Standard) | LPM | 186 | 211 | 327 | 372 |
| | Inlet/Outlet diameter(Water pipe) | mm | 50A/50A | 50A/50A | 65A/65A | 65A/65A |
| Fan motor | Type | BLDC | | | | |
| | No. of Fan | EA | 2 | 2 | 4 | 4 |
| | No. of Vanes(per fan) | EA | 6 | | | |
| | Air Flow Rate | CMM | 246 x 2 @1,000rpm | 246 x 2 @1,000rpm | 246 x 4 @1,000rpm | 246 x 4 @1,000rpm |
| | Motor power | W | 900 x 2 | 900 x 2 | 900 x 4 | 900 x 4 |
| Expansion unit | - | EEV | | | | |
| Weight | kg | 560 | 560 | 1,034 | 1,034 | |
| Dimension | W | mm | 765 | 765 | 1,528 | 1,528 |
| | H | mm | 2,200 | | | |
| | D | mm | 2,154 | | | |
| Footprint | m ² /RT | 0.089 | 0.078 | 0.102 | 0.089 | |
| Protection Devices | High/Low Pressure | - | 0 | | | |
| | Anti Frost | - | 0 | | | |
| Remote Control | - | Modbus | | | | |
| Outlet Temperature | °C | 4~20 | | | | |
| Ambient Temperature | °C | -15~48 | | | | |
| Guaranteed Load Capacity Range | - | 20 % ~ 100 % | | | | |

Note:
 1. Due to our policy of innovation some specifications may be changed without prior notification.
 2. Capacities and Inputs are based on the following conditions.
 Cooling : Outdoor air temp. 35°C, Water inlet temp. 12°C, Water Outlet temp. 7°C
 3. The AHRI Certified® mark indicates LG Electronics participation in the AHRI Certification program. For verification of individual certified products, go to www.ahridirectory.org.
 4. The ACAH***VETB / ACAH***HETB models are certified by AHRI to AHRI Standard 550/590.

460V

| Inverter Scroll Chiller | | Model | ACAH045HETB | ACAH050HETB | ACAH060HETB | ACAH067HETB |
|--------------------------------|---|--------------------|-------------------|-------------------|-------------------|-------------------|
| | | | C/O | C/O | C/O | C/O |
| Power | | Phase, Lines, V | 3, 3, 460 | | | |
| Capacity | kW | 148 | 171 | 195 | 222 | |
| | RT | 42.1 | 48.6 | 55.4 | 63.1 | |
| Input Power | kW | 56.9 | 54.3 | 64.6 | 85.4 | |
| Efficiency | W/W | 2.60 | 3.15 | 3.02 | 2.60 | |
| IPLV | W/W | 5.1 | 5.4 | 5.3 | 5.1 | |
| Sound Pressure | dB(A) | 69 | 68 | 69 | 71 | |
| Compressor | Type | - | Inverter Scroll | | | |
| | No. of Compressor | EA | 4 | 6 | 6 | 6 |
| | Oil Type | - | PVE | | | |
| | Oil charge | cc | 1,400 x 4 | 1,400 x 6 | 1,400 x 6 | 1,400 x 6 |
| Refrigerant | Type | - | R410A | | | |
| | Amount of Charged | kg | 6.5 x 4 | 6.5 x 6 | 6.5 x 6 | 6.5 x 6 |
| Evaporator | Type | - | Shell & Tube | | | |
| | Pressure drop | kPa | 49.2 | 29.6 | 38.8 | 49.2 |
| | Operating maximum pressure(Refrigerant / Water) | kg/cm ² | 42/10 | | | |
| | Water Flow Rate(Standard) | LPM | 422 | 491 | 558 | 633 |
| | Inlet/Outlet diameter(Water pipe) | mm | 65A/65A | | | |
| Fan motor | Type | - | BLDC | | | |
| | No. of Fan | EA | 4 | 6 | 6 | 6 |
| | No. of Vanes(per fan) | EA | 6 | | | |
| | Air Flow Rate | CMM | 246 x 4 @1,000rpm | 246 x 6 @1,000rpm | 246 x 6 @1,000rpm | 246 x 6 @1,000rpm |
| | Motor power | W | 900 x 4 | 900 x 6 | 900 x 6 | 900 x 6 |
| Expansion unit | | - | EEV | | | |
| Weight | | kg | 1,034 | 1,522 | 1,522 | 1,522 |
| Dimension | W | mm | 1,528 | 2,291 | 2,291 | 2,291 |
| | H | mm | 2,200 | | | |
| | D | mm | 2,154 | | | |
| Footprint | | m ² /RT | 0.078 | 0.101 | 0.089 | 0.078 |
| Protection Devices | High/Low Pressure | - | 0 | | | |
| | Anti Frost | - | 0 | | | |
| Remote Control | | - | Modbus | | | |
| Outlet Temperature | | °C | 4~20 | | | |
| Ambient Temperature | | °C | -15~48 | | | |
| Guaranteed Load Capacity Range | | - | 20 % ~ 100 % | | | |

Note:
 1. Due to our policy of innovation some specifications may be changed without prior notification.
 2. Capacities and Inputs are based on the following conditions.
 Cooling : Outdoor air temp. 35°C, Water inlet temp. 12°C, Water Outlet temp. 7°C
 3. The AHRI Certified® mark indicates LG Electronics participation in the AHRI Certification program. For verification of individual certified products, go to www.ahridirectory.org.
 4. The ACAH***VETB / ACAH***HETB models are certified by AHRI to AHRI Standard 550/590.

380-415V

| Inverter Scroll Chiller | | Model | ACHH020LETB | ACHH023LETB | ACHH033LETB | ACHH040LETB | ACHH045LETB |
|-------------------------|-----------------------------------|--------------------|---------------|-------------|-------------|-------------|-------------|
| | | | 1 Unit | | 2 Unit | | |
| Power | | Ph, Lines, V | 3, 4, 380-415 | | | | |
| Capacity | Cooling | kW | 65 | 74 | 114 | 130 | 148 |
| | | RT | 18.5 | 21.0 | 32.4 | 37.0 | 42.1 |
| | Heating | kW | 70 | 80 | 120 | 140 | 160 |
| | | RT | 19.9 | 22.7 | 34.1 | 39.8 | 45.5 |
| Input Power | Cooling | kW | 21.50 | 28.50 | 36.2 | 43.0 | 56.9 |
| | Heating | kW | 23.00 | 28.10 | 38.1 | 45.9 | 56.1 |
| Efficiency | Cooling | W/W | 3.02 | 2.60 | 3.15 | 3.02 | 2.60 |
| | Heating | W/W | 3.05 | 2.85 | 3.15 | 3.05 | 2.85 |
| IPLV | | W/W | 5.3 | 5.1 | 5.4 | 5.3 | 5.1 |
| Sound Pressure | | dB(A) | 63 | 65 | 65 | 66 | 68 |
| Compressor | Type | - | Scroll | | | | |
| | No. of Compressor | EA | 2 | 2 | 4 | 4 | 4 |
| | Oil Type | - | PVE | | | | |
| | Oil charge | cc | 1,400 x 2 | | 1,400 x 4 | | |
| Refrigerant | Type | - | R410A | | | | |
| | Amount of Charged | kg | 6.7 X 2 | | 6.7 X 4 | | |
| Evaporator | Type | - | Shell & Tube | | | | |
| | Operating maximum pressure | kg/cm ² | 42 / 10 | | | | |
| | Standard Flow(Cooling/Heating) | LPM | 186 / 200 | 211 / 229 | 327 / 345 | 372 / 400 | 422 / 458 |
| | Inlet/Outlet diameter(Water pipe) | mm | 50A / 50A | | 65A / 65A | | |
| Expansion unit | | - | EEV | | | | |
| Weight | | kg | 580 | | 1,080 | | |
| Dimension | W | mm | 765 | | 1,528 | | |
| | H | mm | 2,293 | | | | |
| | D | mm | 2,154 | | | | |
| Remote Control | | - | Modbus | | | | |
| Outlet Temperature | Cooling | °C | 4~20 | | | | |
| | Heating | °C | 30~55 | | | | |
| Ambient Temperature | Cooling | °C | -15~48 | | | | |
| | Heating | °C | -30~35 | | | | |
| Earth Leakage Breaker | | A | 60 | 60 | 100 | 100 | 125 |

Note:
 1. Due to our policy of innovation some specifications may be changed without prior notification.
 2. Capacities and Inputs are based on the following conditions.
 Cooling : Outdoor air temp. 35°C, Water inlet temp. 12°C, Water Outlet temp. 7°C Heating : Outdoor air temp. 7°C, Water inlet temp. 40°C, Water Outlet temp. 45°C
 3. Sound pressure level is measured on the rated condition in the anechoic rooms by ISO 3745 standard.

Cooling only

| ACAH | Unit | | Power Supply | | COMP | | OFM | |
|---------|-----------|--------------------|--------------|---------|-----------|------------|---------|------|
| | Voltage | Voltage range | MCA | MFA | MSC | RLA | kW | FLA |
| 020VETB | 208 - 230 | Min: 187, Max: 253 | 72.9 | 100 | 20.4 | 57.5 | 1.8 | 8 |
| 033VETB | 208 - 230 | Min: 187, Max: 253 | 117.4 | 125 | 40.8 | 95.2 | 3.6 | 16 |
| 040VETB | 208 - 230 | Min: 187, Max: 253 | 138.4 | 150 | 40.8 | 115.0 | 3.6 | 16 |
| 050VETB | 208 - 230 | Min: 187, Max: 253 | 117.4+61.8 | 125+80 | 40.7+20.4 | 95.2+47.6 | 3.6+1.8 | 16+8 |
| 060VETB | 208 - 230 | Min: 187, Max: 253 | 138.4+72.9 | 150+100 | 40.7+20.4 | 115.0+57.5 | 3.6+1.8 | 16+8 |
| 020LETB | 380 - 415 | Min: 342, Max: 456 | 39 | 60 | 11.8 | 30.2 | 1.8 | 5 |
| 023LETB | 380 - 415 | Min: 342, Max: 456 | 48 | 60 | 11.8 | 38.2 | 1.8 | 5 |
| 033LETB | 380 - 415 | Min: 342, Max: 456 | 72 | 100 | 23.6 | 55.2 | 3.6 | 10 |
| 040LETB | 380 - 415 | Min: 342, Max: 456 | 78 | 100 | 23.6 | 60.4 | 3.6 | 10 |
| 045LETB | 380 - 415 | Min: 342, Max: 456 | 96 | 125 | 23.6 | 76.4 | 3.6 | 10 |
| 050LETB | 380 - 415 | Min: 342, Max: 456 | 108 | 125 | 35.4 | 82.8 | 5.4 | 15 |
| 060LETB | 380 - 415 | Min: 342, Max: 456 | 117 | 125 | 35.4 | 90.6 | 5.4 | 15 |
| 067LETB | 380 - 415 | Min: 342, Max: 456 | 144 | 200 | 35.4 | 114.6 | 5.4 | 15 |
| 020HETB | 460 | Min: 414, Max: 506 | 31.0 | 50 | 9.7 | 24.9 | 1.8 | 5 |
| 023HETB | 460 | Min: 414, Max: 506 | 41.2 | 50 | 9.7 | 31.6 | 1.8 | 5 |
| 033HETB | 460 | Min: 414, Max: 506 | 48.4 | 60 | 19.5 | 45.6 | 3.6 | 10 |
| 040HETB | 460 | Min: 414, Max: 506 | 59.0 | 80 | 19.5 | 49.9 | 3.6 | 10 |
| 045HETB | 460 | Min: 414, Max: 506 | 78.2 | 100 | 19.5 | 63.1 | 3.6 | 10 |
| 050HETB | 460 | Min: 414, Max: 506 | 71.4 | 100 | 29.2 | 68.4 | 5.4 | 15 |
| 060HETB | 460 | Min: 414, Max: 506 | 87.0 | 125 | 29.2 | 74.8 | 5.4 | 15 |
| 067HETB | 460 | Min: 414, Max: 506 | 115.2 | 150 | 29.2 | 94.7 | 5.4 | 15 |

Heat pump

| ACHH | Unit | | | Power Supply | | COMP | | OFM | |
|---------|------|---------|------------------|--------------|-----|------|------|-----|-----|
| | Hz | Volt | Voltage Range | MCA | MFA | MSC | RLA | kW | FLA |
| 020LETB | 60 | 380-415 | Min:342, Max:456 | 39 | 60 | 11.8 | 30.3 | 1.8 | 5 |
| 023LETB | 60 | 380-415 | Min:342, Max:456 | 48 | 60 | 11.8 | 39.0 | 1.8 | 5 |
| 033LETB | 60 | 380-415 | Min:342, Max:456 | 72 | 100 | 23.6 | 56.6 | 3.6 | 10 |
| 040LETB | 60 | 380-415 | Min:342, Max:456 | 78 | 100 | 23.6 | 60.6 | 3.6 | 10 |
| 045LETB | 60 | 380-415 | Min:342, Max:456 | 96 | 125 | 23.6 | 78.0 | 3.6 | 10 |

MCA: Minimum Circuit Ampere, A
MFA: Maximum Fuse Ampere, A
RLA: Rated Load Ampere, A
MSC: Maximum Start Current, A

Note:

1. RLA is the current required when operated in the following condition. Cooling : Outdoor air temp. 27°C DB / 19.0°C WB, Water inlet / Outlet temp. 12°C / 7°C Heating : Outdoor air temp. 7°C DB / 6.0°C WB, Water inlet / Outlet temp. 40.0°C / 45.0°C
 2. Voltage range
The chiller must be operated at the voltage within the upper and lower limit supplied from the power terminal to operate normally.
 3. Maximum voltage variance permitted between phases is 2%.
 4. MCA is the criteria of selecting the wiring standard.
 5. MFA is used when selecting circuit breaker and grounding error circuit breaker(Electricity leakage circuit breaker).
- * For Russia only, MCA of ACAH033LETB is 76.

ACAH Series 1 Unit

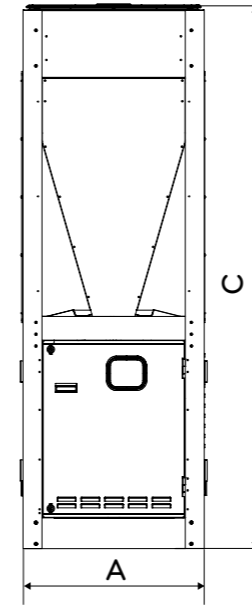

Front view

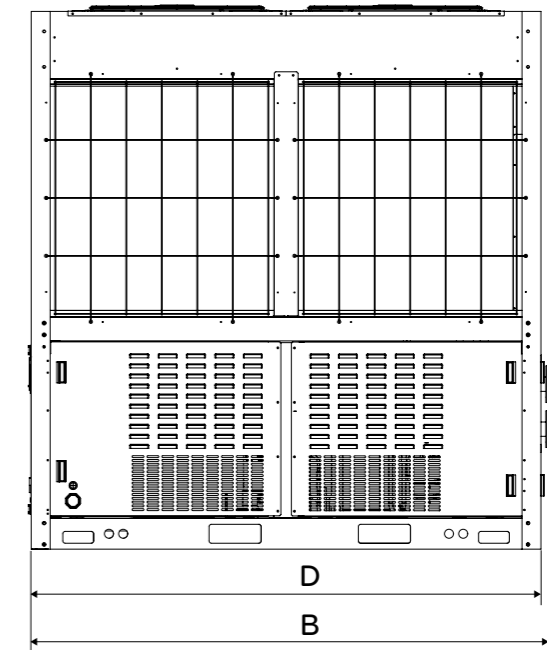

Side view

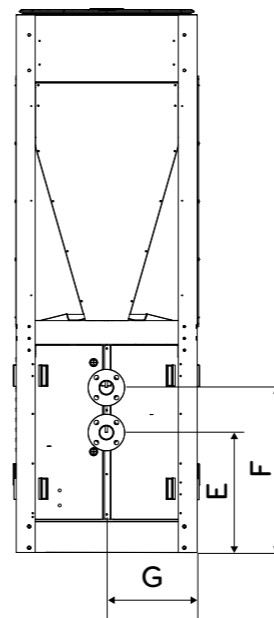

Rear view

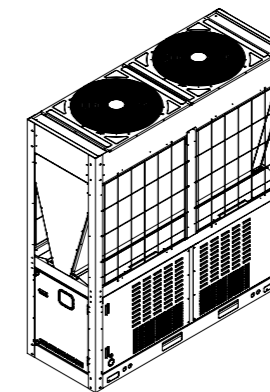

(Unit : mm)

| Classification | Dimension |
|----------------|-----------|
| A | 765 |
| B | 2,198 |
| C | 2,200 |
| D | 2,154 |
| E | 507 |
| F | 700 |
| G | 384 |

Outline dimension



ACAH Series 2 Unit

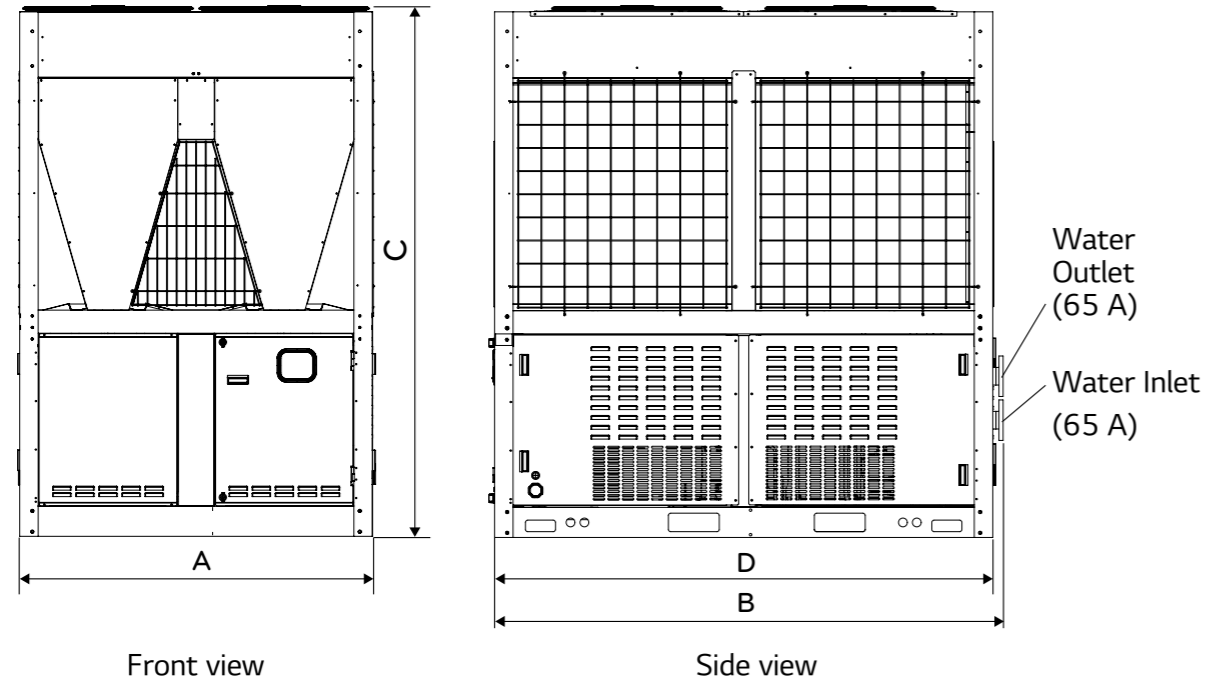

Outline dimension



ACAH Series 3 Unit

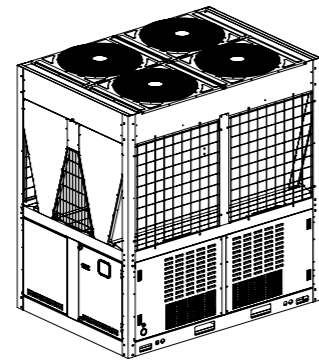
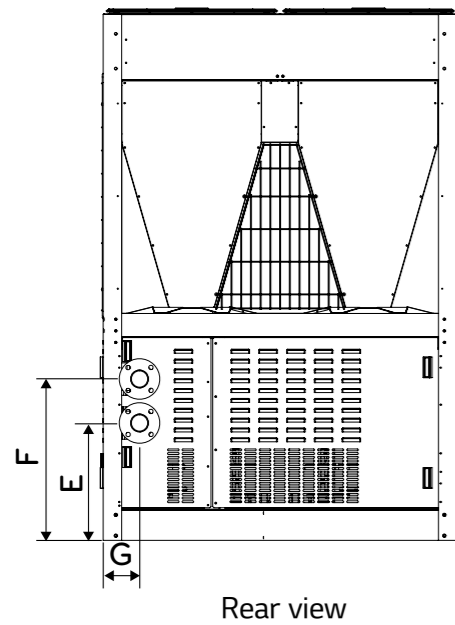
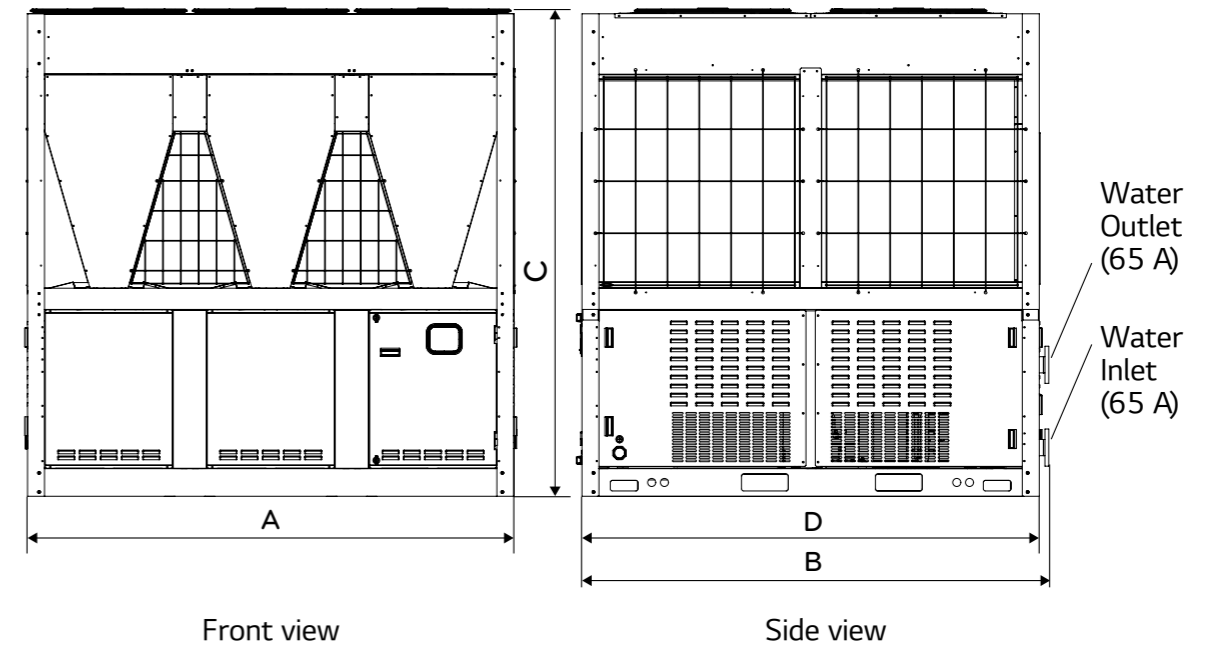

(Unit : mm)

| Classification | Dimension |
|----------------|-----------|
| A | 1,528 |
| B | 2,199 |
| C | 2,200 |
| D | 2,154 |
| E | 434 |
| F | 700 |
| G | 157 |

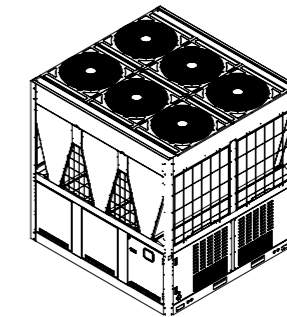
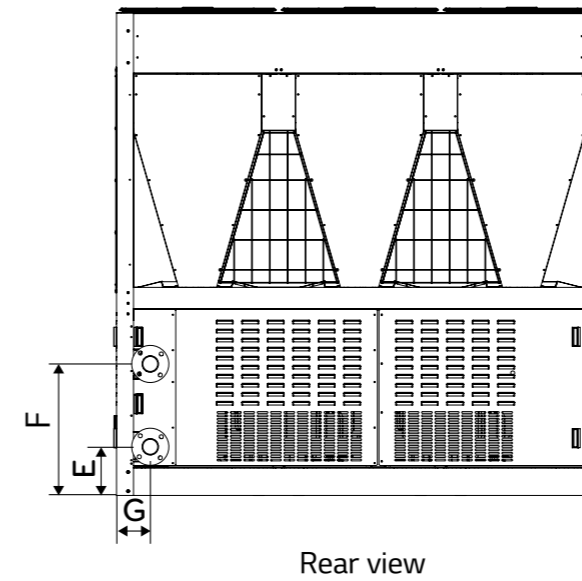

(Unit : mm)

| Classification | Dimension |
|----------------|-----------|
| A | 2,291 |
| B | 2,199 |
| C | 2,200 |
| D | 2,154 |
| E | 434 |
| F | 700 |
| G | 157 |

Outline dimension

ACHH Series 1 Unit

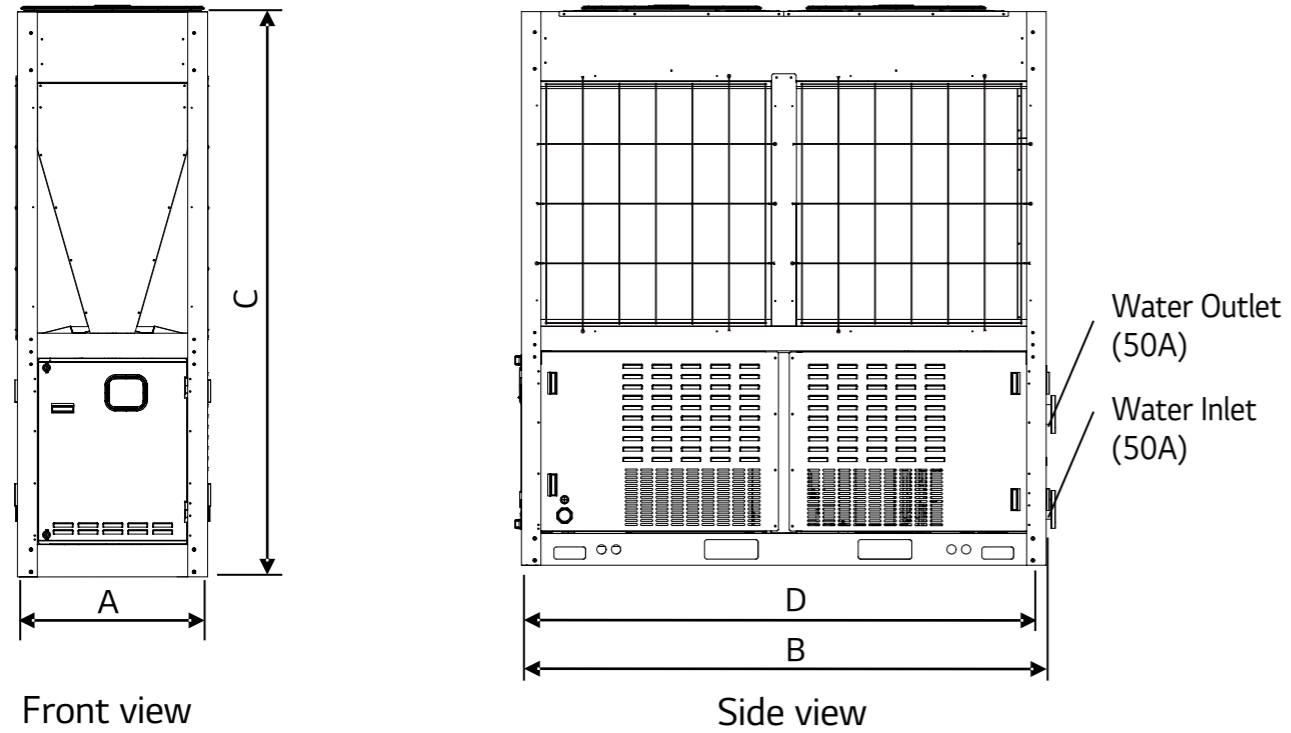

Outline dimension

ACHH Series 2 Unit

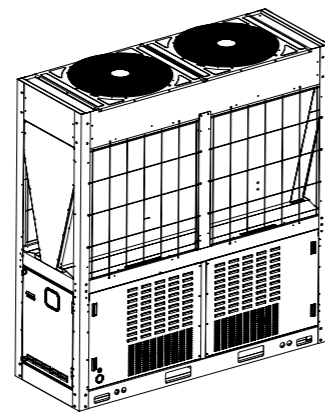
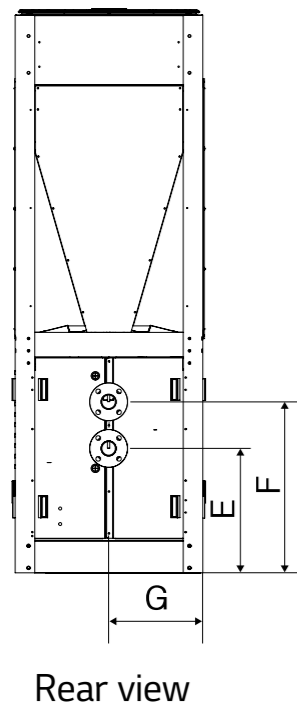
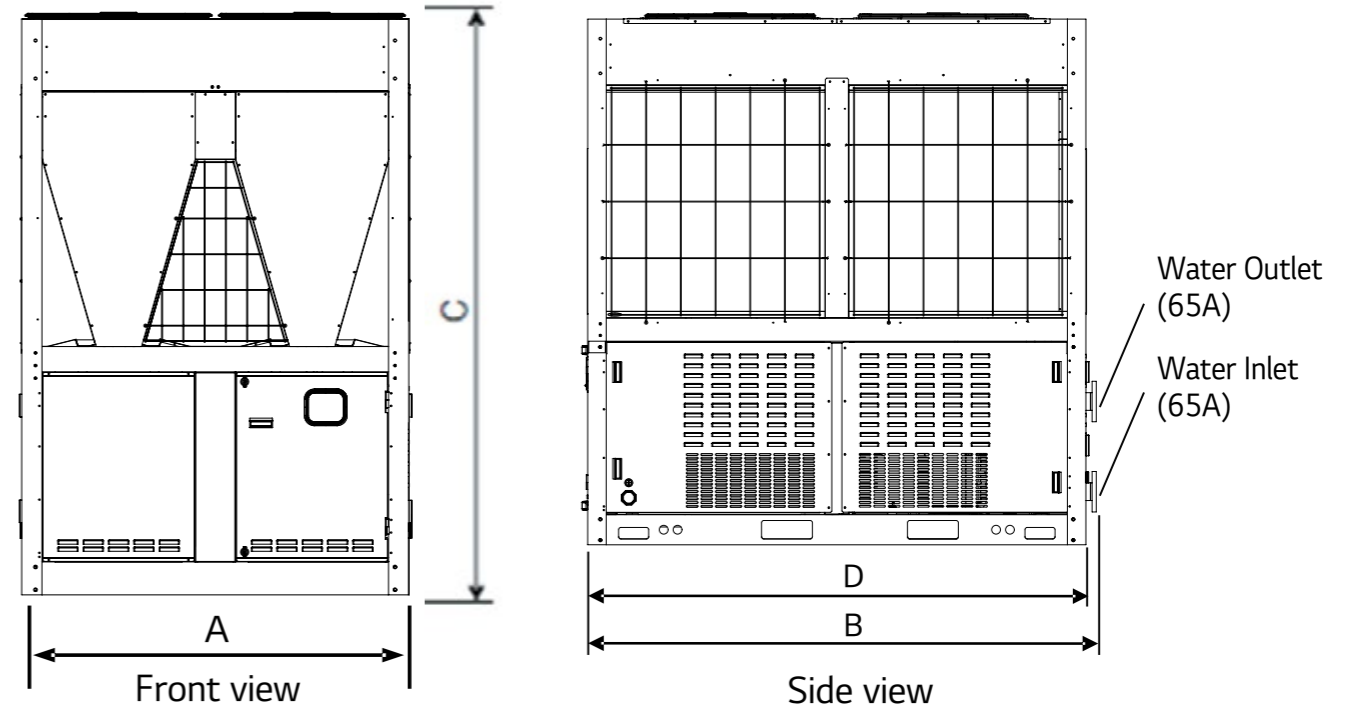

(Unit : mm)

| Classification | Dimension |
|----------------|-----------|
| A | 765 |
| B | 2,198 |
| C | 2,293 |
| D | 2,154 |
| E | 507 |
| F | 700 |
| G | 384 |

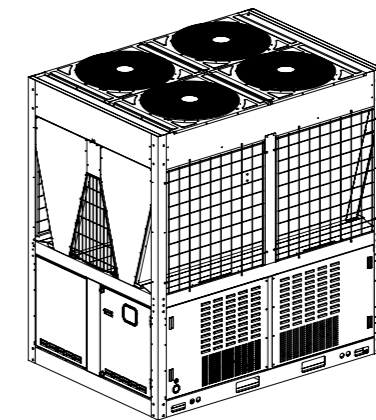
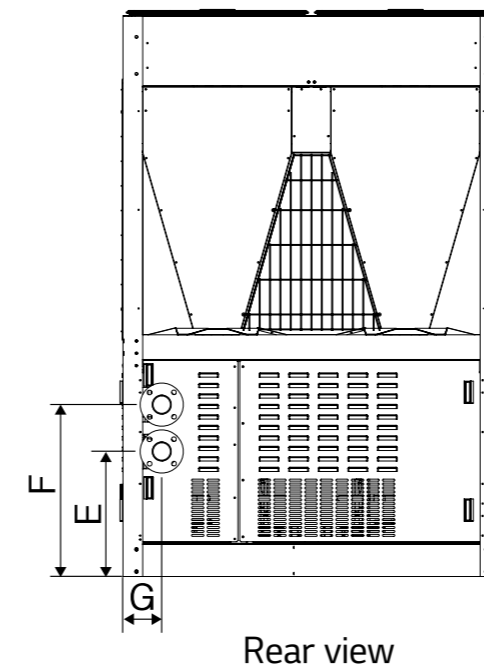

(Unit : mm)

| Classification | Dimension |
|----------------|-----------|
| A | 1,528 |
| B | 2,198 |
| C | 2,293 |
| D | 2,154 |
| E | 434 |
| F | 700 |
| G | 157 |

Details to consider when installing the base

- The base must be able to withstand concentrated load.
- The base must be installed with maximum gradient of 1/300.
- The height of the base must be higher than the surface of the water and drain holes must be installed around.
- Set the height of the base according to the installation environment so that the product is not submerged in water.
The default height of the base is 200mm and it must be at least doubled in areas with double the snowfall of 100mm or above.
- Install the drain pipe in the drain hole.
- The drainage must be finished so that particles around the drainage do not clog the pipes.
- LG is not responsible for product failure or damage from incorrectly designed or manufactured base.

Shape of anchor bolt

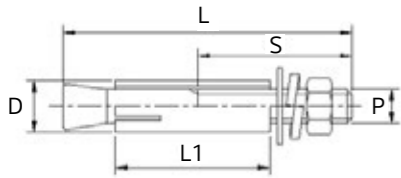

Specification of anchor bolt

| Screw size(d) | L | S | D | L1 | Used drill | Depth of drill(min.) | Pullout load(N) |
|---------------|-----|----|----|----|------------|----------------------|-----------------|
| 15.88mm(M16) | 125 | 70 | 22 | 65 | 22 | 65 | 42,140 |

Dimension

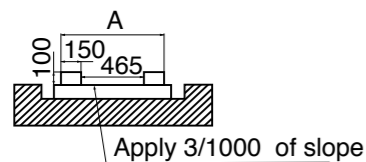
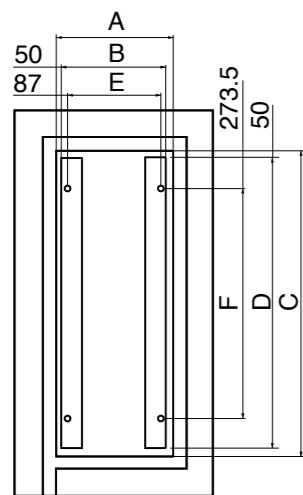

1 Unit Drawing of base

Shape of anchor bolt

[Unit: mm]

| | 1 Unit | 2 Unit | 3 Unit |
|---|--------|--------|--------|
| A | 865 | 1,630 | 2,391 |
| B | 765 | 1,528 | 2,291 |
| C | 2,254 | 2,254 | 2,254 |
| D | 2,154 | 2,154 | 2,154 |
| E | 691 | 1,456 | 2,217 |
| F | 1,707 | 1,707 | 1,707 |

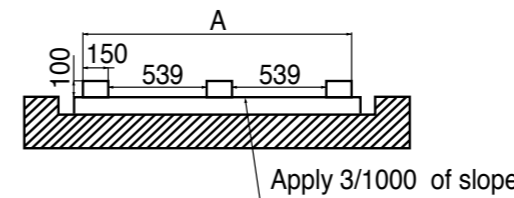
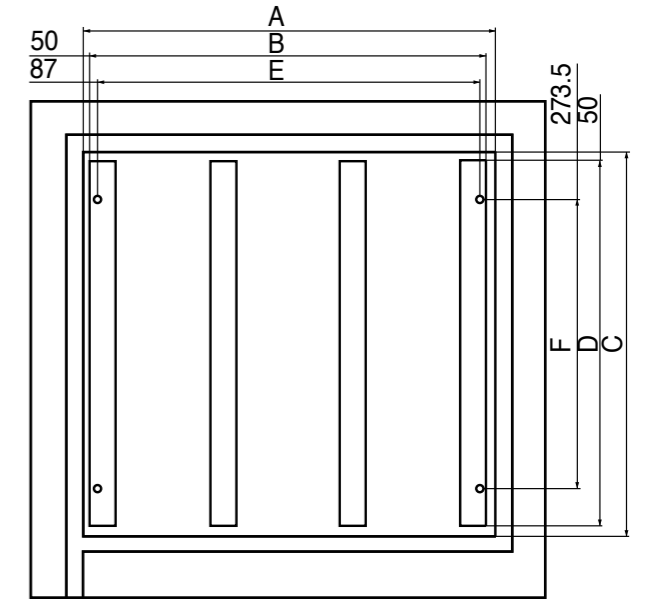
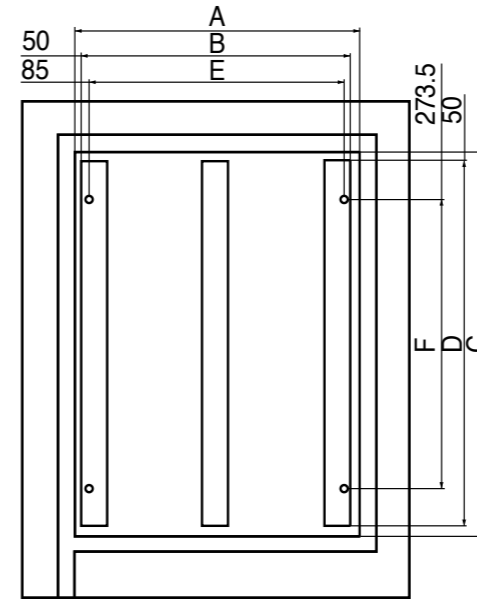
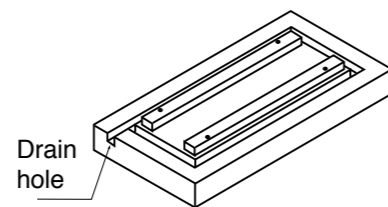

2 Unit Drawing of base

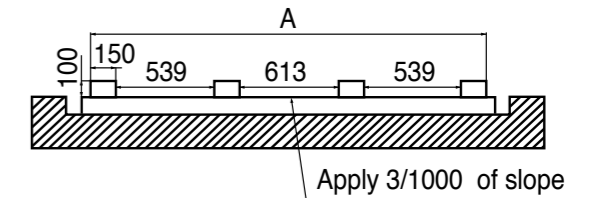

3 Unit Drawing of base

Piping diagram

ACAH Series 1 Unit

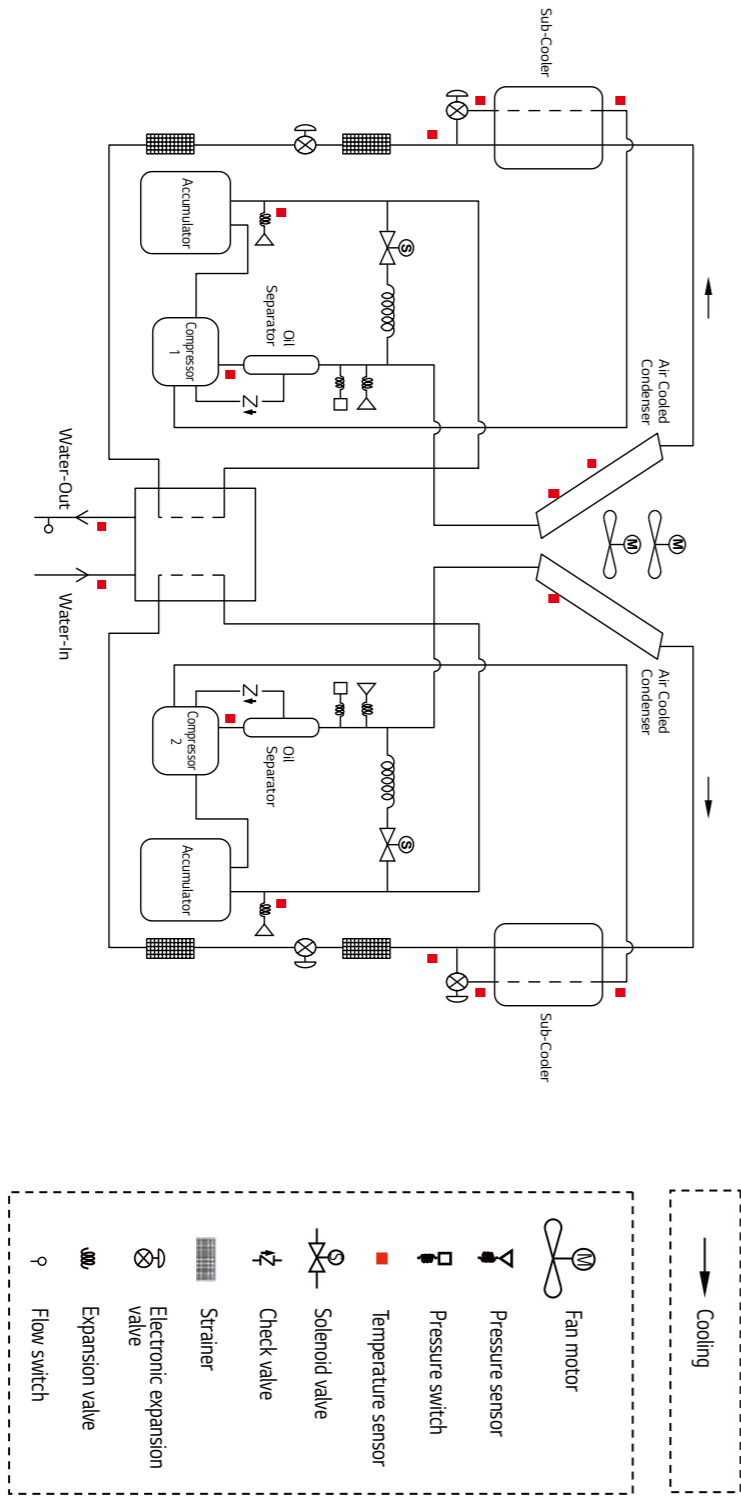

Piping diagram

ACAH Series 2 Unit

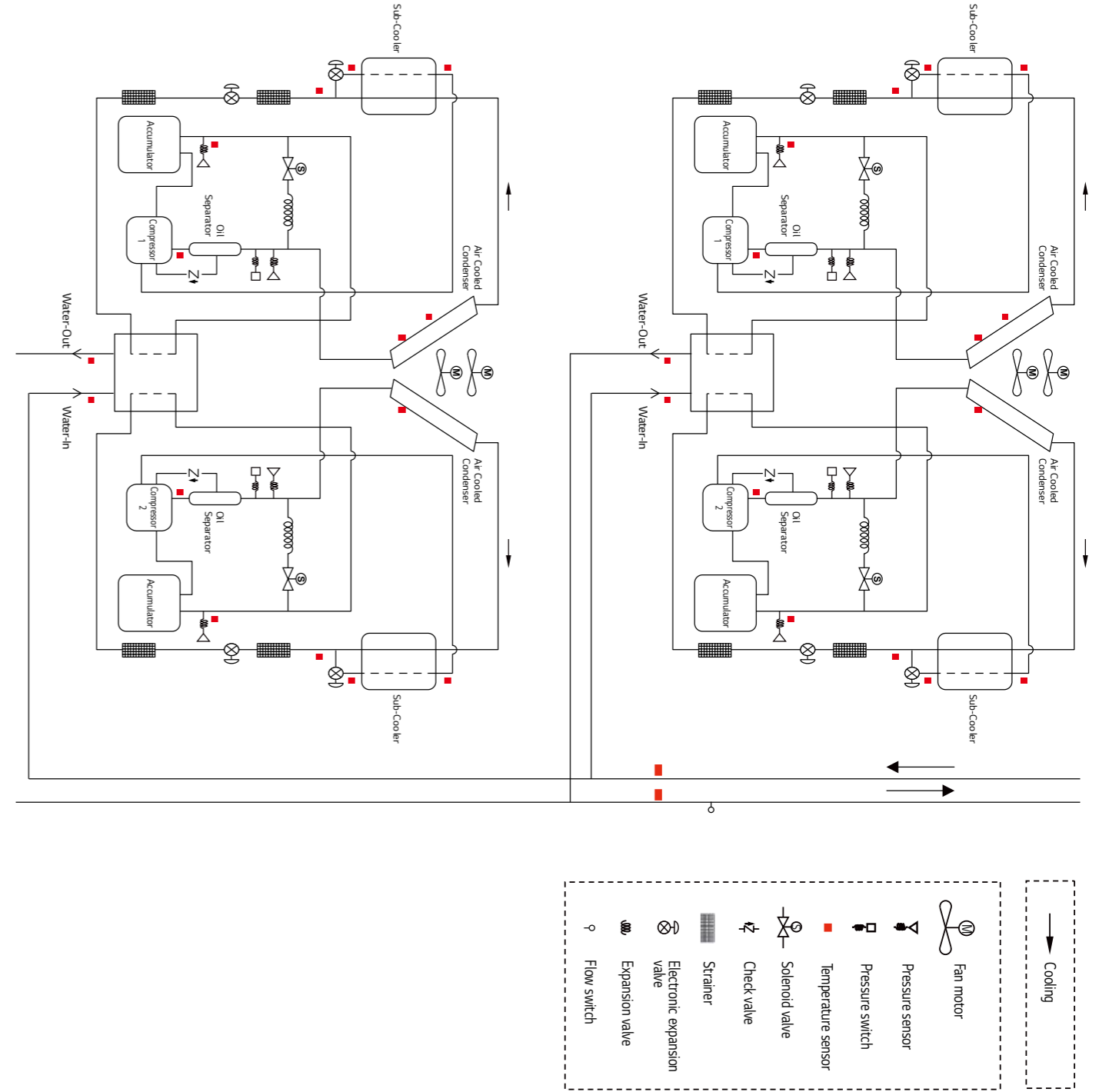

ACAH Series 3 Unit

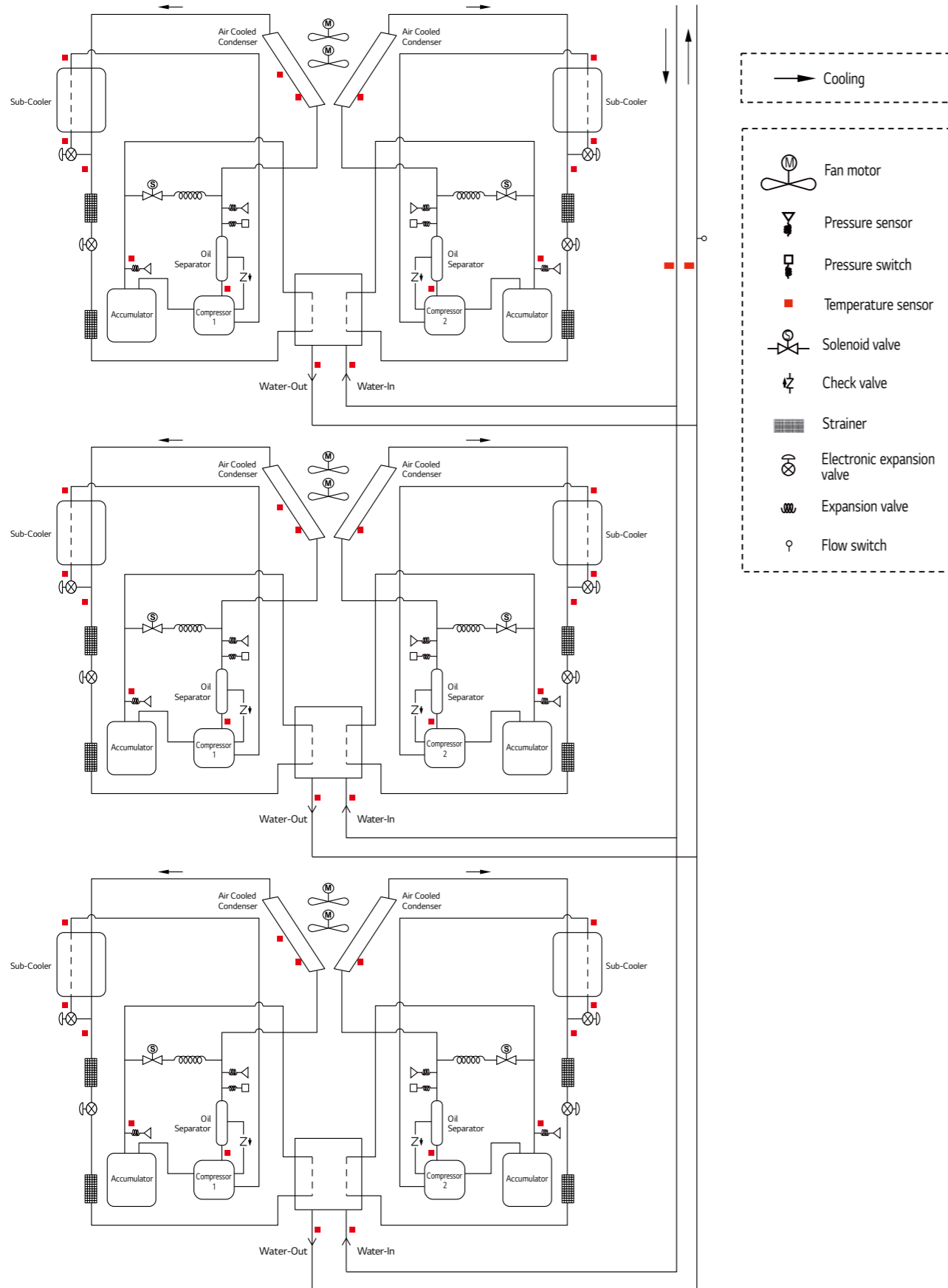

ACHH Series 1 Unit

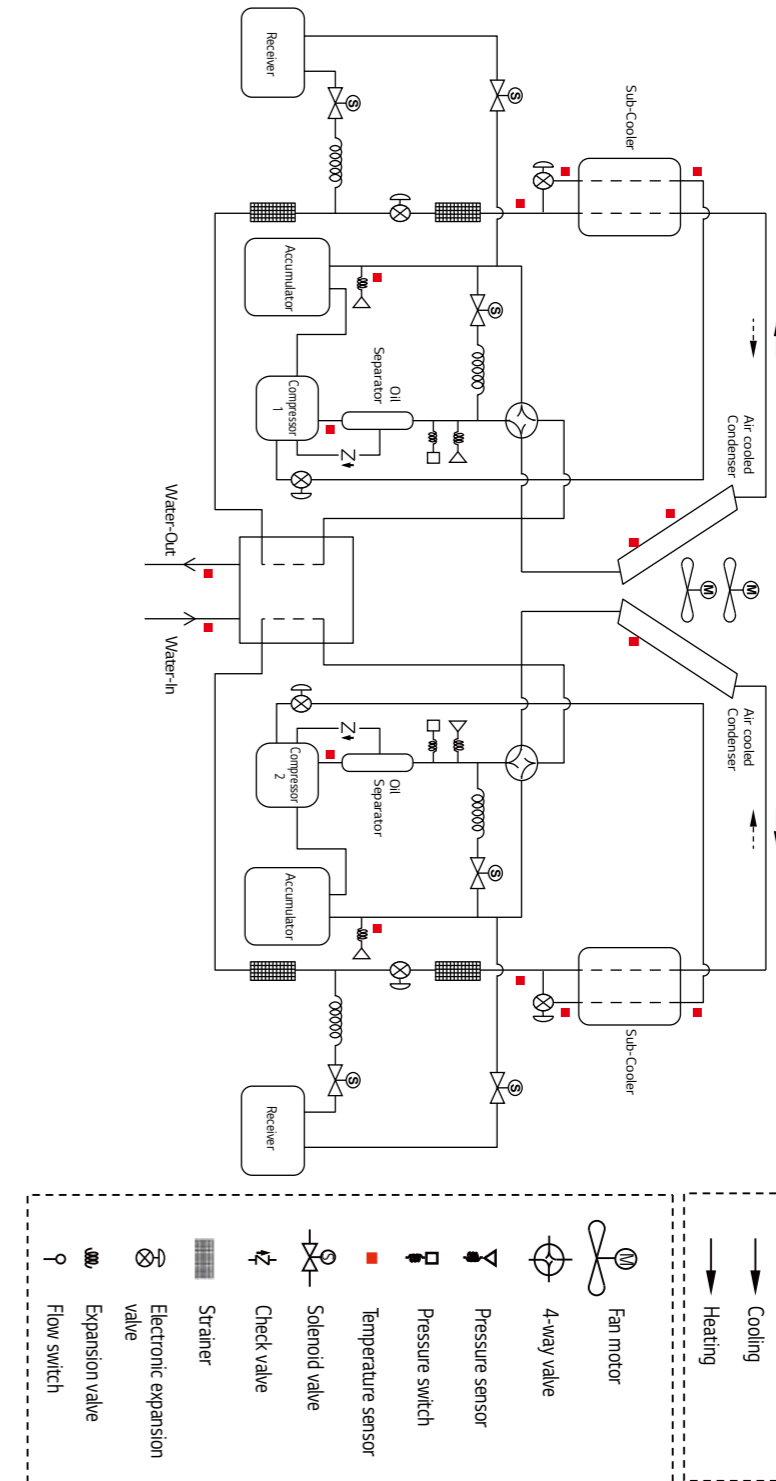

ACHH Series 2 Unit

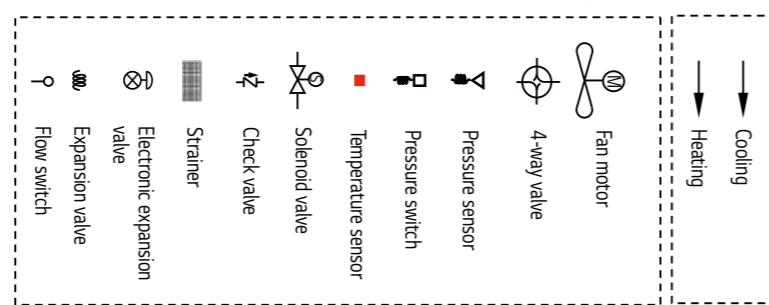
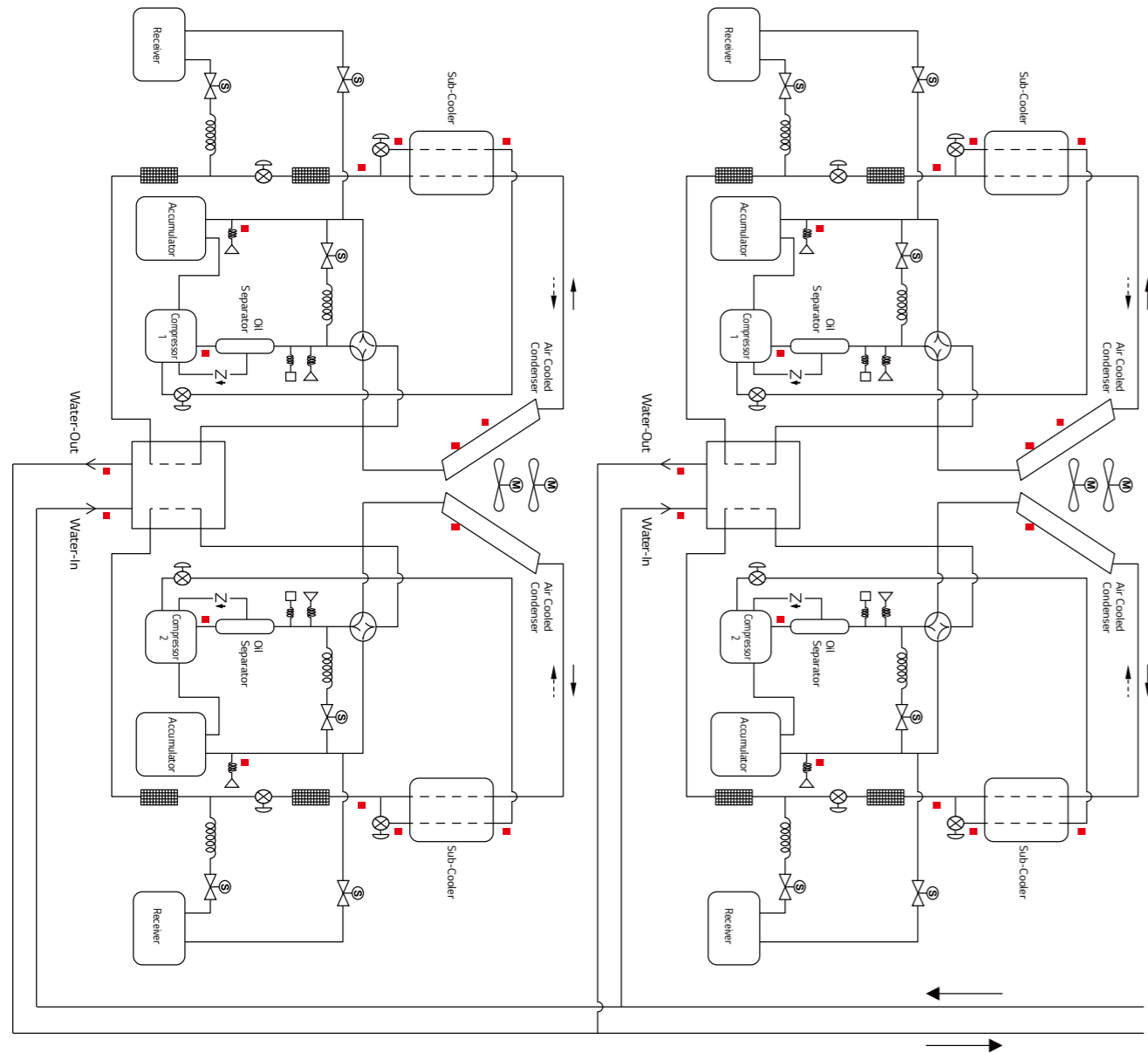

1 Unit, 2 Unit(Main), 3 Unit(Main)

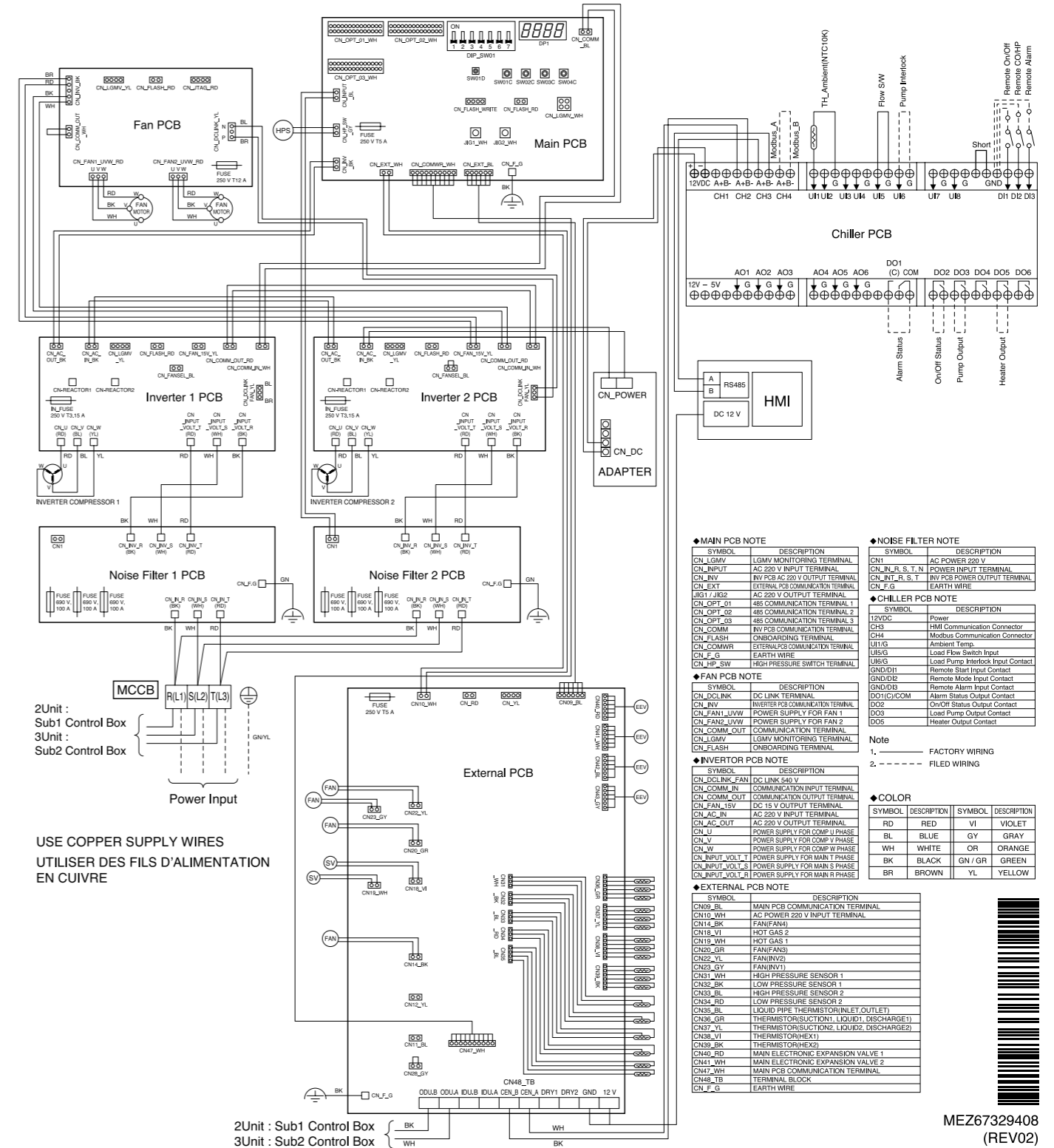

◆ MAIN PCB NOTE

| SYMBOL | DESCRIPTION |
|-----------|-------------------------------------|
| CN_LGMV | LG MV MONITORING TERMINAL |
| CN_INPU1 | AC 220 V INPUT TERMINAL |
| CN_INV | RV PCB AC 220 V OUTPUT TERMINAL |
| CN_EXT | EXTERNAL PCB COMMUNICATION TERMINAL |
| CN_I1E2 | AC 220 V OUTPUT TERMINAL |
| CN_OPT_G1 | 485 COMMUNICATION TERMINAL 1 |
| CN_OPT_G2 | 485 COMMUNICATION TERMINAL 2 |
| CN_OPT_G3 | 485 COMMUNICATION TERMINAL 3 |
| CN_COMM | RV PCB COMMUNICATION TERMINAL |
| CN_FLASH | ONBOARDING TERMINAL |
| CN_COMMW | EXTERNAL PCB COMMUNICATION TERMINAL |
| CN_F_G | EARTH WIRE |
| CN_HP_SW | HIGH PRESSURE SWITCH TERMINAL |

◆ NOISE FILTER NOTE

| SYMBOL | DESCRIPTION |
|----------|----------------------|
| CN_LIN_R | AC POWER 220 V |
| CN_IN_R | POWER INPUT TERMINAL |
| CN_F_G | EARTH WIRE |

◆ CHILLER PCB NOTE

| SYMBOL | DESCRIPTION |
|---------|-----------------------------------|
| 12VDC | Power |
| CH4 | HMI Communication Connector |
| CH4 | Modbus Communication Connector |
| U15/G | Ambient Temp. |
| U15/G | Load Flow Switch Input |
| U15/G | Load Pump Interlock Input Contact |
| GND/D11 | Remote Start Input Contact |
| GND/D12 | Remote Mode Input Contact |
| GND/D13 | Remote Alarm Input Contact |
| DO1/COM | Alarm Status Output Contact |
| DO2 | On/Off Status Output Contact |
| DO3 | Load Pump Output Contact |
| DO5 | Heater Output Contact |

◆ FAN PCB NOTE

| SYMBOL | DESCRIPTION |
|-----------------|-------------------------------|
| CN_DLINK_FAN | DC LINK 540 V |
| CN_COMM_IN | COMMUNICATION INPUT TERMINAL |
| CN_COMM_OUT | COMMUNICATION OUTPUT TERMINAL |
| CN_FAN_15V | DC 15 V OUTPUT TERMINAL |
| CN_AC_IN | AC 220 V INPUT TERMINAL |
| CN_AC_OUT | AC 220 V OUTPUT TERMINAL |
| CN_U | POWER SUPPLY FOR COMP U PHASE |
| CN_V | POWER SUPPLY FOR COMP V PHASE |
| CN_W | POWER SUPPLY FOR COMP W PHASE |
| CN_INPUT_VOLT_S | POWER SUPPLY FOR MAIN S PHASE |
| CN_INPUT_VOLT_T | POWER SUPPLY FOR MAIN T PHASE |
| CN_INPUT_VOLT_R | POWER SUPPLY FOR MAIN R PHASE |

◆ EXTERNAL PCB NOTE

| SYMBOL | DESCRIPTION |
|---------|---|
| CN09_BK | MAIN PCB COMMUNICATION TERMINAL |
| CN10_WH | AC POWER 220 V INPUT TERMINAL |
| CN14_BK | FAN(FAN1) |
| CN18_VI | HOT GAS 2 |
| CN19_WH | HOT GAS 1 |
| CN20_GR | FAN(FAN3) |
| CN22_VI | FAN(INV2) |
| CN23_GY | FAN(INV1) |
| CN31_WH | HIGH PRESSURE SENSOR 1 |
| CN32_BK | LOW PRESSURE SENSOR 1 |
| CN33_BK | HIGH PRESSURE SENSOR 2 |
| CN34_RD | LOW PRESSURE SENSOR 2 |
| CN35_BK | LIQUID PIPE THERMISTOR(INLET/OUTLET) |
| CN36_GR | THERMISTOR(SUCTION1, LIQUID1, DISCHARGE1) |
| CN37_VI | THERMISTOR(SUCTION2, LIQUID2, DISCHARGE2) |
| CN38_VI | THERMISTOR(HEX1) |
| CN39_BK | THERMISTOR(HEX2) |
| CN40_RD | MAIN ELECTRONIC EXPANSION VALVE 1 |
| CN41_WH | MAIN ELECTRONIC EXPANSION VALVE 2 |
| CN47_WH | MAIN PCB COMMUNICATION TERMINAL |
| CN48_TB | TERMINAL BLOCK |
| CN_F_G | EARTH WIRE |

Note
1. _____ FACTORY WIRING
2. - - - - - FILED WIRING

◆ COLOR

| SYMBOL | DESCRIPTION | SYMBOL | DESCRIPTION |
|--------|-------------|---------|-------------|
| RD | RED | VI | VIOLET |
| BL | BLUE | GY | GRAY |
| WH | WHITE | OR | ORANGE |
| BK | BLACK | GN / GR | GREEN |
| BR | BROWN | YL | YELLOW |

MEZ67329408 (REV02)

1 Unit, 2 Unit(Main), 3 Unit(Main)

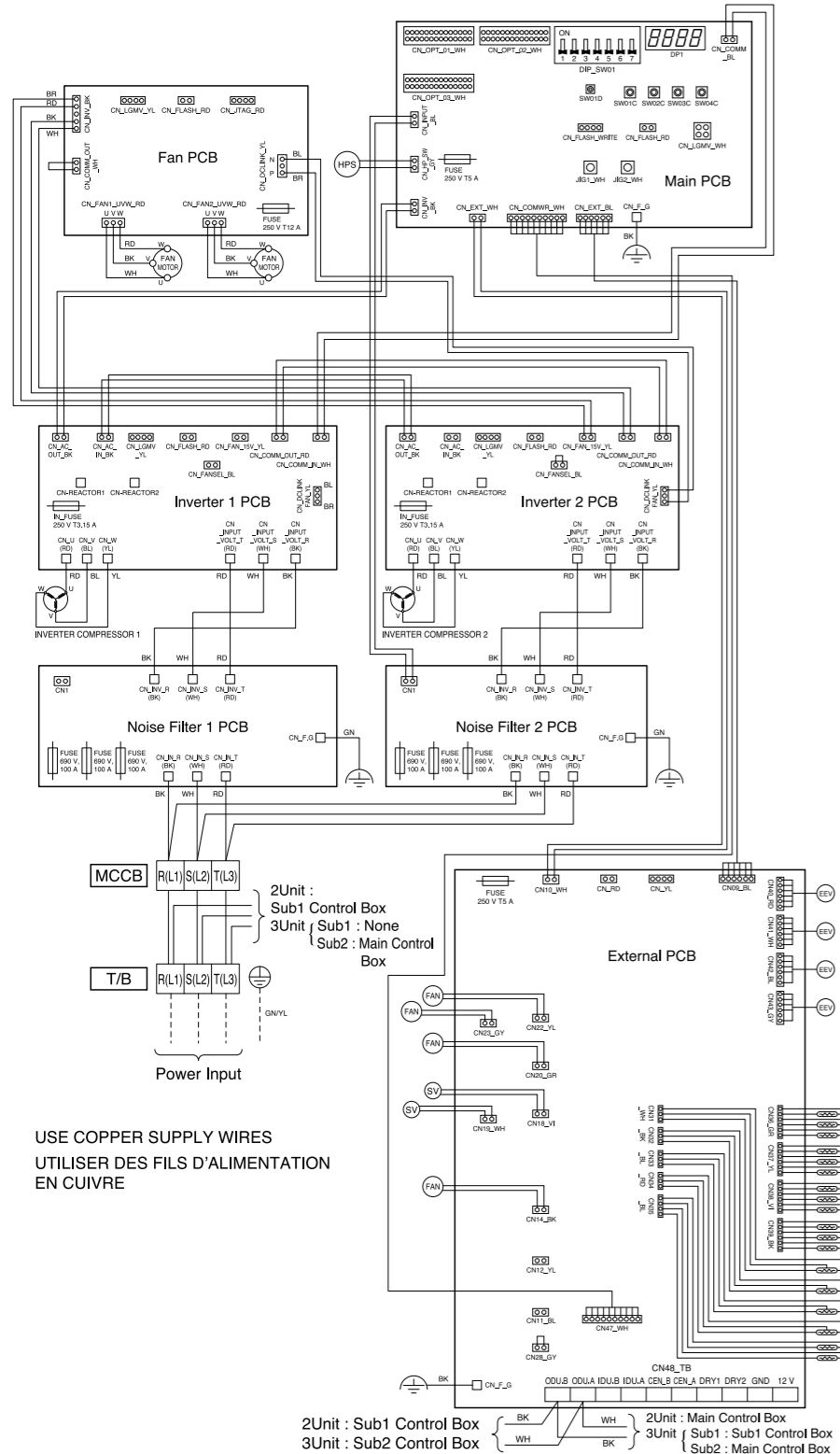

◆MAIN PCB NOTE

| SYMBOL | DESCRIPTION |
|-----------|-------------------------------------|
| CN_LGMV | LGMV MONITORING TERMINAL |
| CN_INVN | AC 220 V INPUT TERMINAL |
| CN_INVV | INV PCB AC 220 V OUTPUT TERMINAL |
| CN_EXT | EXTERNAL PCB COMMUNICATION TERMINAL |
| JIG1/JIG2 | AC 220 V OUTPUT TERMINAL |
| CN_OPT_01 | 485 COMMUNICATION TERMINAL 1 |
| CN_OPT_02 | 485 COMMUNICATION TERMINAL 2 |
| CN_OPT_03 | 485 COMMUNICATION TERMINAL 3 |
| CN_COMM | INV PCB COMMUNICATION TERMINAL |
| CN_FLASH | ONBOARDING TERMINAL |
| CN_COMMWR | EXTERNAL PCB COMMUNICATION TERMINAL |
| CN_F_G | EARTH WIRE |
| CN_SW | HIGH PRESSURE SWITCH TERMINAL |

◆FAN PCB NOTE

| SYMBOL | DESCRIPTION |
|---------------|-------------------------------|
| CN_DCLINK_FAN | DC LINK 540 V |
| CN_COMM_IN | COMMUNICATION INPUT TERMINAL |
| CN_COMM_OUT | COMMUNICATION OUTPUT TERMINAL |
| CN_FAN_L1VW | POWER SUPPLY FOR FAN 1 |
| CN_FAN_L2VW | POWER SUPPLY FOR FAN 2 |
| CN_COMM_OUT | COMMUNICATION TERMINAL |
| CN_LGMV | LGMV MONITORING TERMINAL |
| CN_FLASH | ONBOARDING TERMINAL |

◆EXTERNAL PCB NOTE

| SYMBOL | DESCRIPTION |
|---------|--|
| CN09_BL | MAIN PCB COMMUNICATION TERMINAL |
| CN10_WH | AC POWER 220 V INPUT TERMINAL |
| CN14_BK | FAN(FAN4) |
| CN18_VI | HOT GAS 2 |
| CN18_WH | HOT GAS 1 |
| CN20_GR | FAN(FAN3) |
| CN22_YL | FAN(INV2) |
| CN23_GY | FAN(INV1) |
| CN21_WH | HIGH PRESSURE SENSOR 1 |
| CN23_BK | LOW PRESSURE SENSOR 1 |
| CN23_RD | LOW PRESSURE SENSOR 2 |
| CN23_BL | HIGH PRESSURE SENSOR 2 |
| CN24_RD | LOW PRESSURE SENSOR 2 |
| CN25_BL | LIQUID PIPE THERMISTOR(INLET, OUTLET) |
| CN26_GR | THERMISTOR(SUCTON1, LIQUID1, DISCHARGE1) |
| CN27_TL | THERMISTOR(SUCTON2, LIQUID2, DISCHARGE2) |
| CN28_VI | THERMISTOR(HEX1) |
| CN29_BK | THERMISTOR(HEX2) |
| CN40_RD | MAIN ELECTRONIC EXPANSION VALVE 1 |
| CN41_WH | MAIN ELECTRONIC EXPANSION VALVE 2 |
| CN47_WH | MAIN PCB COMMUNICATION TERMINAL |
| CN48_TB | TERMINAL BLOCK |
| CN_F_G | EARTH WIRE |

◆NOISE FILTER NOTE

| SYMBOL | DESCRIPTION |
|---------|-------------------------------|
| CN1 | AC POWER 220 V |
| CN_IN_V | INV PCB POWER OUTPUT TERMINAL |
| CN_F_G | EARTH WIRE |

◆COLOR

| SYMBOL | DESCRIPTION | SYMBOL | DESCRIPTION |
|--------|-------------|---------|-------------|
| RD | RED | VI | VIOLET |
| BL | BLUE | GY | GRAY |
| WH | WHITE | OR | ORANGE |
| BK | BLACK | GN / GR | GREEN |
| BR | BROWN | YL | YELLOW |

◆MAIN PCB NOTE

| SYMBOL | DESCRIPTION |
|-----------|-------------------------------------|
| CN_LGMV | LGMV MONITORING TERMINAL |
| CN_INVN | AC 220 V INPUT TERMINAL |
| CN_INVV | INV PCB AC 220 V OUTPUT TERMINAL |
| CN_EXT | EXTERNAL PCB COMMUNICATION TERMINAL |
| JIG1/JIG2 | AC 220 V OUTPUT TERMINAL |
| CN_OPT_01 | 485 COMMUNICATION TERMINAL 1 |
| CN_OPT_02 | 485 COMMUNICATION TERMINAL 2 |
| CN_OPT_03 | 485 COMMUNICATION TERMINAL 3 |
| CN_COMM | INV PCB COMMUNICATION TERMINAL |
| CN_FLASH | ONBOARDING TERMINAL |
| CN_COMMWR | EXTERNAL PCB COMMUNICATION TERMINAL |
| CN_F_G | EARTH WIRE |
| CN_SW | HIGH PRESSURE SWITCH TERMINAL |

◆FAN PCB NOTE

| SYMBOL | DESCRIPTION |
|---------------|-------------------------------|
| CN_DCLINK_FAN | DC LINK 540 V |
| CN_COMM_IN | COMMUNICATION INPUT TERMINAL |
| CN_COMM_OUT | COMMUNICATION OUTPUT TERMINAL |
| CN_FAN_L1VW | POWER SUPPLY FOR FAN 1 |
| CN_FAN_L2VW | POWER SUPPLY FOR FAN 2 |
| CN_COMM_OUT | COMMUNICATION TERMINAL |
| CN_LGMV | LGMV MONITORING TERMINAL |
| CN_FLASH | ONBOARDING TERMINAL |

◆EXTERNAL PCB NOTE

| SYMBOL | DESCRIPTION |
|---------|--|
| CN09_BL | MAIN PCB COMMUNICATION TERMINAL |
| CN10_WH | AC POWER 220 V INPUT TERMINAL |
| CN14_BK | FAN(FAN4) |
| CN18_VI | HOT GAS 2 |
| CN18_WH | HOT GAS 1 |
| CN20_GR | FAN(FAN3) |
| CN22_YL | FAN(INV2) |
| CN23_GY | FAN(INV1) |
| CN21_WH | HIGH PRESSURE SENSOR 1 |
| CN23_BK | LOW PRESSURE SENSOR 1 |
| CN23_RD | LOW PRESSURE SENSOR 2 |
| CN23_BL | HIGH PRESSURE SENSOR 2 |
| CN24_RD | LOW PRESSURE SENSOR 2 |
| CN25_BL | LIQUID PIPE THERMISTOR(INLET, OUTLET) |
| CN26_GR | THERMISTOR(SUCTON1, LIQUID1, DISCHARGE1) |
| CN27_TL | THERMISTOR(SUCTON2, LIQUID2, DISCHARGE2) |
| CN28_VI | THERMISTOR(HEX1) |
| CN29_BK | THERMISTOR(HEX2) |
| CN40_RD | MAIN ELECTRONIC EXPANSION VALVE 1 |
| CN41_WH | MAIN ELECTRONIC EXPANSION VALVE 2 |
| CN47_WH | MAIN PCB COMMUNICATION TERMINAL |
| CN48_TB | TERMINAL BLOCK |
| CN_F_G | EARTH WIRE |

MEZ67329409 (REV02)

1 Unit, 2 Unit(Main), 3 Unit(Main)

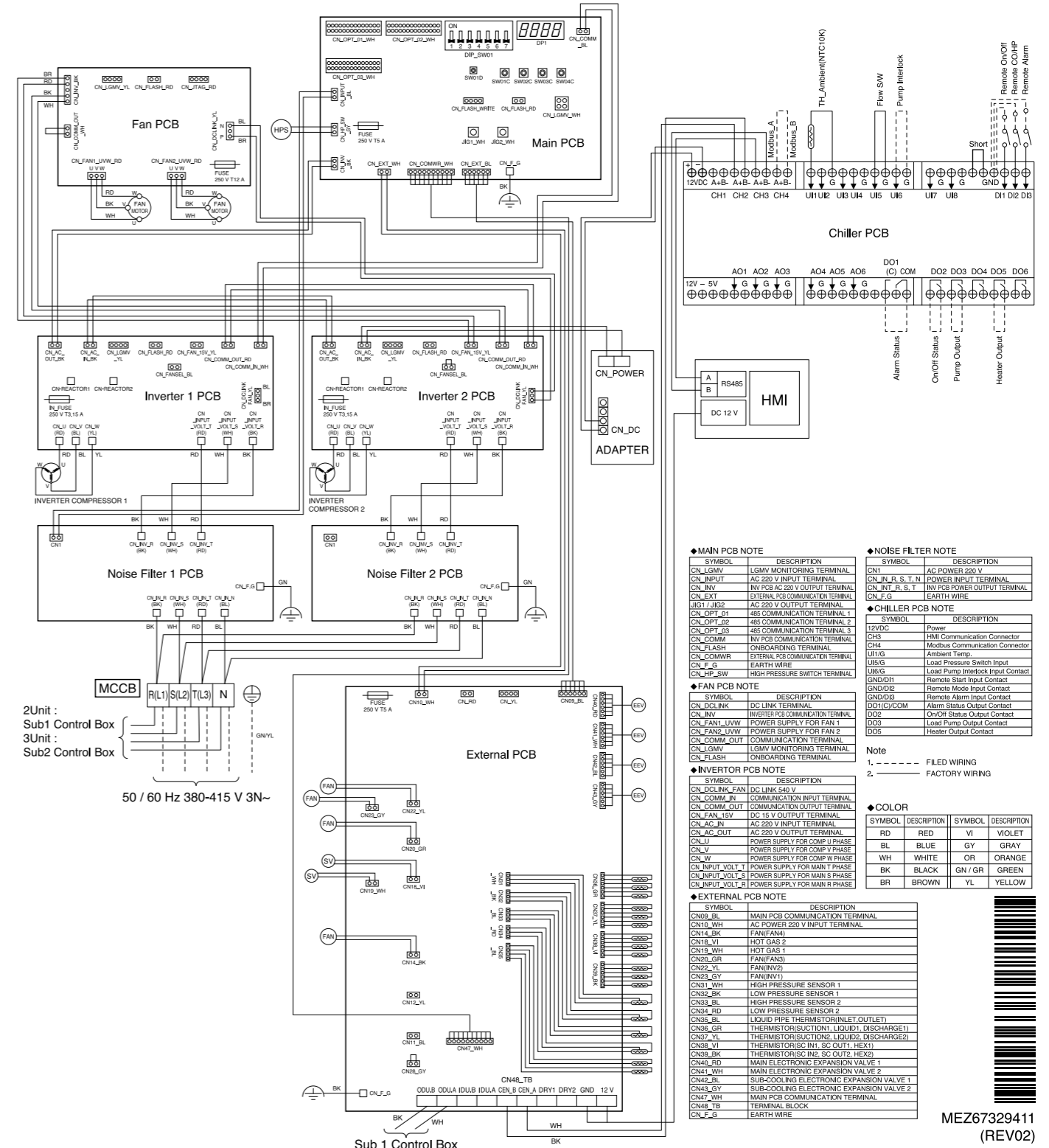

◆MAIN PCB NOTE

| SYMBOL | DESCRIPTION |
|-----------|-------------------------------------|
| CN_LGMV | LGMV MONITORING TERMINAL |
| CN_INVN | AC 220 V INPUT TERMINAL |
| CN_INVV | INV PCB AC 220 V OUTPUT TERMINAL |
| CN_EXT | EXTERNAL PCB COMMUNICATION TERMINAL |
| JIG1/JIG2 | AC 220 V OUTPUT TERMINAL |
| CN_OPT_01 | 485 COMMUNICATION TERMINAL 1 |
| CN_OPT_02 | 485 COMMUNICATION TERMINAL 2 |
| CN_OPT_03 | 485 COMMUNICATION TERMINAL 3 |
| CN_COMM | INV PCB COMMUNICATION TERMINAL |
| CN_FLASH | ONBOARDING TERMINAL |
| CN_COMMWR | EXTERNAL PCB COMMUNICATION TERMINAL |
| CN_F_G | EARTH WIRE |
| CN_SW | HIGH PRESSURE SWITCH TERMINAL |

◆FAN PCB NOTE

| SYMBOL | DESCRIPTION |
|---------------|-------------------------------|
| CN_DCLINK_FAN | DC LINK 540 V |
| CN_COMM_IN | COMMUNICATION INPUT TERMINAL |
| CN_COMM_OUT | COMMUNICATION OUTPUT TERMINAL |
| CN_FAN_L1VW | POWER SUPPLY FOR FAN 1 |
| CN_FAN_L2VW | POWER SUPPLY FOR FAN 2 |
| CN_COMM_OUT | COMMUNICATION TERMINAL |
| CN_LGMV | LGMV MONITORING TERMINAL |
| CN_FLASH | ONBOARDING TERMINAL |

◆EXTERNAL PCB NOTE

| SYMBOL | DESCRIPTION |
|---------|--|
| CN09_BL | MAIN PCB COMMUNICATION TERMINAL |
| CN10_WH | AC POWER 220 V INPUT TERMINAL |
| CN14_BK | FAN(FAN4) |
| CN18_VI | HOT GAS 2 |
| CN18_WH | HOT GAS 1 |
| CN20_GR | FAN(FAN3) |
| CN22_YL | FAN(INV2) |
| CN23_GY | FAN(INV1) |
| CN21_WH | HIGH PRESSURE SENSOR 1 |
| CN23_BK | LOW PRESSURE SENSOR 1 |
| CN23_RD | LOW PRESSURE SENSOR 2 |
| CN23_BL | HIGH PRESSURE SENSOR 2 |
| CN24_RD | LOW PRESSURE SENSOR 2 |
| CN25_BL | LIQUID PIPE THERMISTOR(INLET, OUTLET) |
| CN26_GR | THERMISTOR(SUCTON1, LIQUID1, DISCHARGE1) |
| CN27_TL | THERMISTOR(SUCTON2, LIQUID2, DISCHARGE2) |
| CN28_VI | THERMISTOR(HEX1) |
| CN29_BK | THERMISTOR(HEX2) |
| CN40_RD | MAIN ELECTRONIC EXPANSION VALVE 1 |
| CN41_WH | MAIN ELECTRONIC EXPANSION VALVE 2 |
| CN47_WH | MAIN PCB COMMUNICATION TERMINAL |
| CN48_TB | TERMINAL BLOCK |
| CN_F_G | EARTH WIRE |

◆NOISE FILTER NOTE

| SYMBOL | DESCRIPTION |
|---------|-------------------------------|
| CN1 | AC POWER 220 V |
| CN_IN_V | INV PCB POWER OUTPUT TERMINAL |
| CN_F_G | EARTH WIRE |

◆CHILLER PCB NOTE

| SYMBOL | DESCRIPTION |
|------------|----------------------------------|
| 12VDC | Power |
| CH3 | HMI Communication Connector |
| CH4 | Modbus Communication Connector |
| U1/U2 | Ambient Temp. |
| U3/G | Load Pressure Switch Input |
| U4/G | Load Pump Feedback Input Contact |
| GND/D01 | Remote Alarm Input Contact |
| GND/D02 | Remote Alarm Input Contact |
| GND/D03 | Remote Alarm Input Contact |
| D01(C)/COM | Alarm Status Output Contact |
| D02 | On/Off Status Output Contact |
| D03 | Load Pump Output Contact |
| D05 | Heater Output Contact |

◆COLOR

| SYMBOL | DESCRIPTION | SYMBOL | DESCRIPTION |
|--------|-------------|---------|-------------|
| RD | RED | VI | VIOLET |
| BL | BLUE | GY | GRAY |
| WH | WHITE | OR | ORANGE |
| BK | BLACK | GN / GR | GREEN |
| BR | BROWN | YL | YELLOW |

MEZ67329411 (REV02)

2 Unit(Sub), 3 Unit(Sub2)

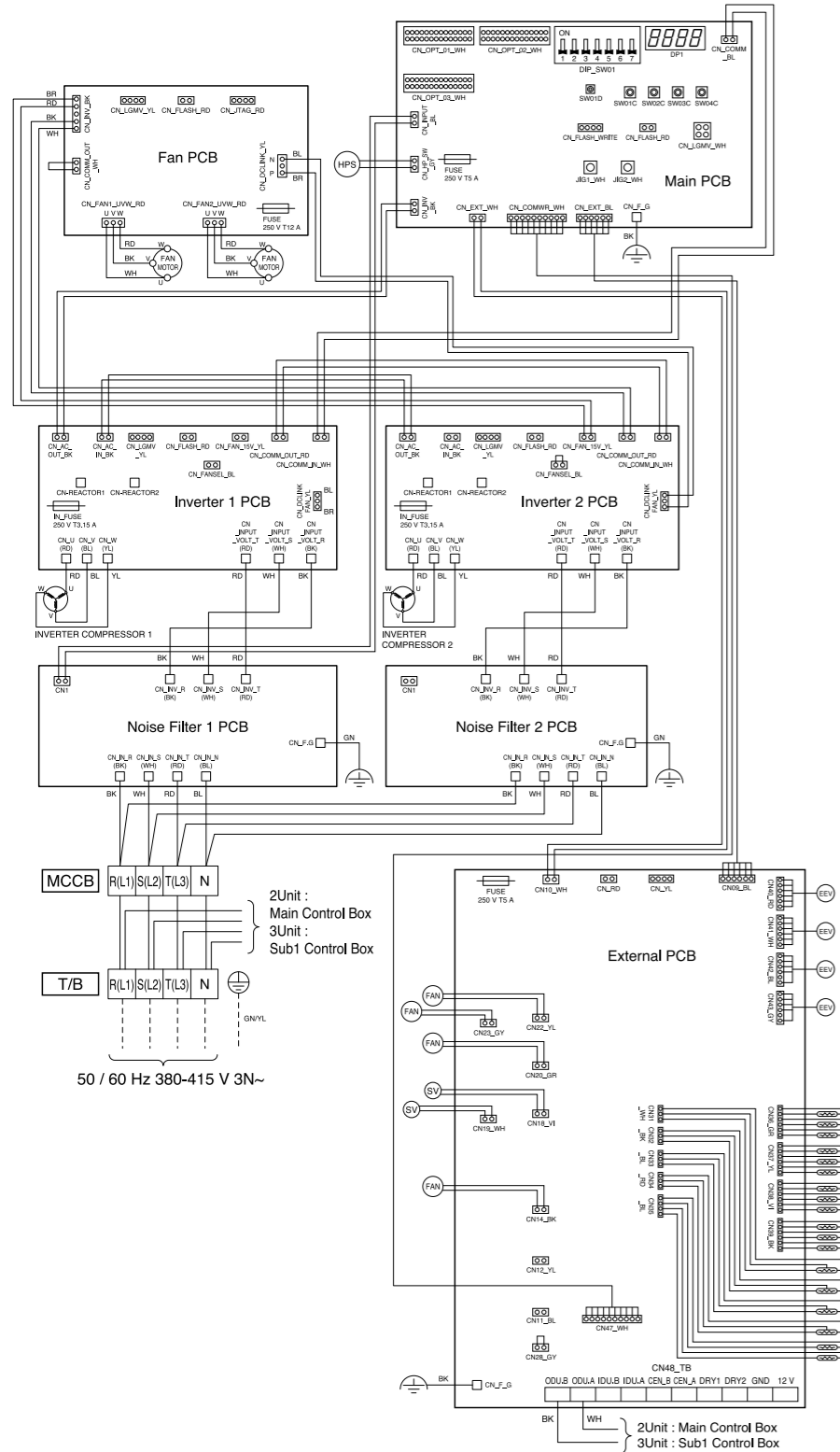

◆MAIN PCB NOTE

| SYMBOL | DESCRIPTION |
|-------------|-------------------------------------|
| CN_LGMV | LGMV MONITORING TERMINAL |
| CN_INPUT | AC 220 V INPUT TERMINAL |
| CN_INV | INV PCB AC 220 V OUTPUT TERMINAL |
| CN_EXT | EXTERNAL PCB COMMUNICATION TERMINAL |
| CN_OPT_01 | 48S COMMUNICATION TERMINAL 1 |
| JIG1 / JIG2 | AC 220 V OUTPUT TERMINAL |
| CN_OPT_02 | 48S COMMUNICATION TERMINAL 2 |
| CN_OPT_03 | 48S COMMUNICATION TERMINAL 3 |
| CN_COMM | INV PCB COMMUNICATION TERMINAL |
| CN_FLASH | ONBOARDING TERMINAL |
| CN_COMMWR | EXTERNAL PCB COMMUNICATION TERMINAL |
| CN_F_G | EARTH WIRE |
| CN_HP_SW | HIGH PRESSURE SWITCH TERMINAL |

◆FAN PCB NOTE

| SYMBOL | DESCRIPTION |
|-------------|-------------------------------------|
| CN_DCLINK | DC LINK TERMINAL |
| CN_INV | INVERTER PCB COMMUNICATION TERMINAL |
| CN_FAN1_UVW | POWER SUPPLY FOR FAN 1 |
| CN_FAN2_UVW | POWER SUPPLY FOR FAN 2 |
| CN_COMM_OUT | COMMUNICATION TERMINAL |
| CN_LGMV | LGMV MONITORING TERMINAL |
| CN_FLASH | ONBOARDING TERMINAL |

◆INVERTER PCB NOTE

| SYMBOL | DESCRIPTION |
|-----------------|-------------------------------|
| CN_DCLINK_FAN | DC LINK 540 V |
| CN_COMM_IN | COMMUNICATION INPUT TERMINAL |
| CN_COMM_OUT | COMMUNICATION OUTPUT TERMINAL |
| CN_FAN_TSV | DC 15 V OUTPUT TERMINAL |
| CN_AC_IN | AC 220 V INPUT TERMINAL |
| CN_AC_OUT | AC 220 V OUTPUT TERMINAL |
| CN_U | POWER SUPPLY FOR COMP U PHASE |
| CN_V | POWER SUPPLY FOR COMP V PHASE |
| CN_W | POWER SUPPLY FOR COMP W PHASE |
| CN_INPUT_VOLT_T | POWER SUPPLY FOR MAIN T PHASE |
| CN_INPUT_VOLT_S | POWER SUPPLY FOR MAIN S PHASE |
| CN_INPUT_VOLT_R | POWER SUPPLY FOR MAIN R PHASE |

◆EXTERNAL PCB NOTE

| SYMBOL | DESCRIPTION |
|---------|--|
| CN20_BK | MAIN PCB COMMUNICATION TERMINAL |
| CN10_WH | AC POWER 220 V INPUT TERMINAL |
| CN14_BK | FAN(FAN4) |
| CN16_VI | HOT GAS 2 |
| CN18_WH | HOT GAS 1 |
| CN20_GR | FAN(FAN3) |
| CN22_YL | FAN(FAN2) |
| CN23_GY | FAN(FAN1) |
| CN31_WH | HIGH PRESSURE SENSOR 1 |
| CN32_BK | LOW PRESSURE SENSOR 1 |
| CN33_BK | HIGH PRESSURE SENSOR 2 |
| CN34_RD | LOW PRESSURE SENSOR 2 |
| CN35_BK | LIQUID PIPE THERMISTOR(INLET OUTLET) |
| CN36_BK | THERMISTOR(SUCTON1; LIQUID; DISCHARGE1) |
| CN37_YL | THERMISTOR(SUCTON2; LIQUID; DISCHARGE2) |
| CN38_VI | THERMISTOR(SC IN; SC OUT1; HEX1) |
| CN39_BK | THERMISTOR(SC IN; SC OUT2; HEX2) |
| CN40_RD | MAIN ELECTRONIC EXPANSION VALVE 1 |
| CN41_WH | MAIN ELECTRONIC EXPANSION VALVE 2 |
| CN42_BK | SUB-COOLING ELECTRONIC EXPANSION VALVE 1 |
| CN43_GY | SUB-COOLING ELECTRONIC EXPANSION VALVE 2 |
| CN47_WH | MAIN PCB COMMUNICATION TERMINAL |
| CN48_TB | TERMINAL BLOCK |
| CN_F_G | EARTH WIRE |

◆NOISE FILTER NOTE

| SYMBOL | DESCRIPTION |
|------------------|-------------------------------|
| CN1 | AC POWER 220 V |
| CN_IN_R, S, T, N | POWER INPUT TERMINAL |
| CN_OUT_R, S, T | INV PCB POWER OUTPUT TERMINAL |
| CN_F_G | EARTH WIRE |

◆COLOR

| SYMBOL | DESCRIPTION | SYMBOL | DESCRIPTION |
|--------|-------------|---------|-------------|
| RD | RED | VI | VIOLET |
| BL | BLUE | GY | GRAY |
| WH | WHITE | OR | ORANGE |
| BK | BLACK | GN / GR | GREEN |
| BR | BROWN | YL | YELLOW |

Note
1. - - - - - FILED WIRING
2. - - - - - FACTORY WIRING

MEZ67329412 (REV02)

3 Unit(Sub1)

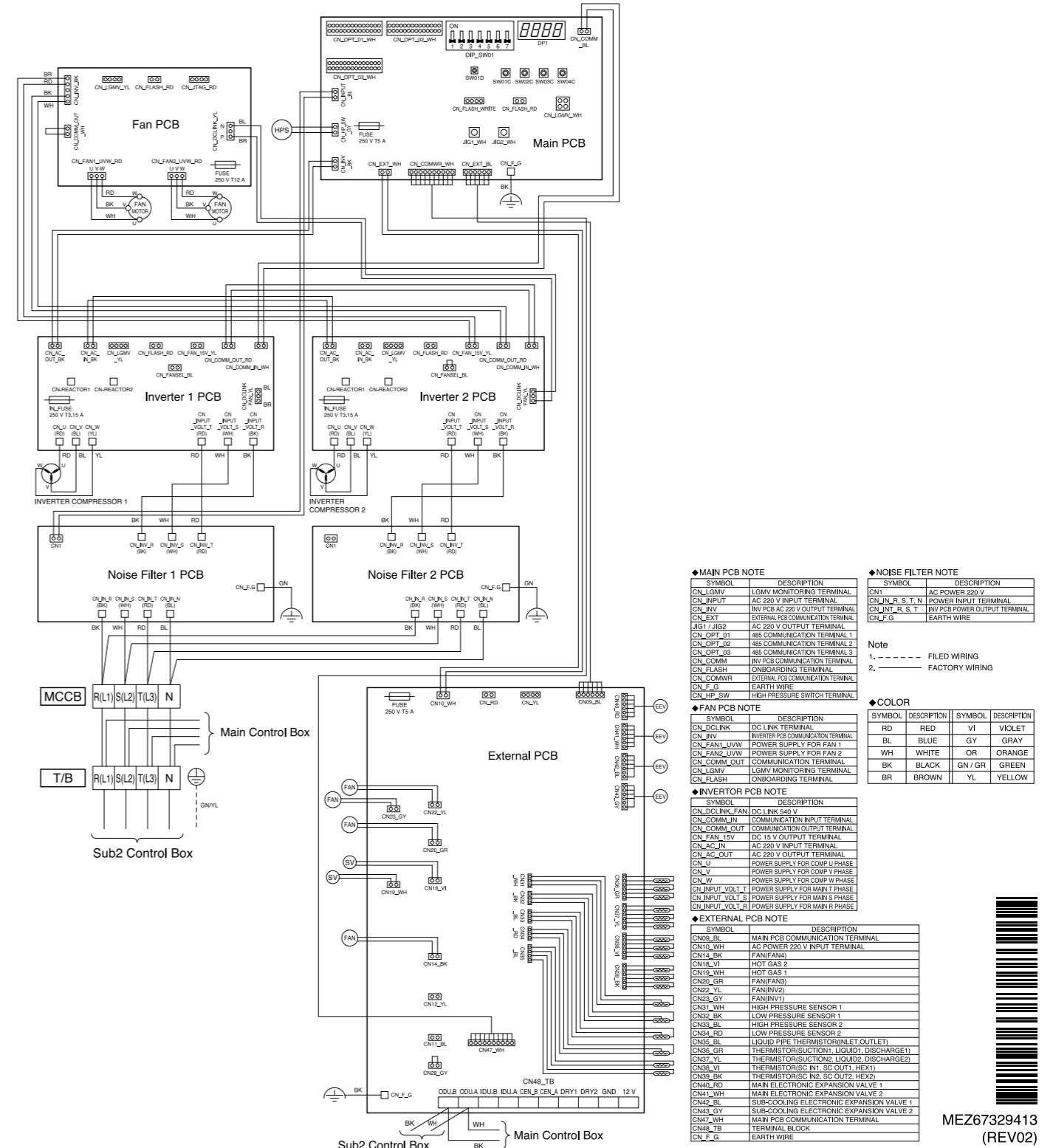

◆MAIN PCB NOTE

| SYMBOL | DESCRIPTION |
|-------------|-------------------------------------|
| CN_LGMV | LGMV MONITORING TERMINAL |
| CN_INPUT | AC 220 V INPUT TERMINAL |
| CN_INV | INV PCB AC 220 V OUTPUT TERMINAL |
| CN_EXT | EXTERNAL PCB COMMUNICATION TERMINAL |
| CN_OPT_01 | 48S COMMUNICATION TERMINAL 1 |
| JIG1 / JIG2 | AC 220 V OUTPUT TERMINAL |
| CN_OPT_02 | 48S COMMUNICATION TERMINAL 2 |
| CN_OPT_03 | 48S COMMUNICATION TERMINAL 3 |
| CN_COMM | INV PCB COMMUNICATION TERMINAL |
| CN_FLASH | ONBOARDING TERMINAL |
| CN_COMMWR | EXTERNAL PCB COMMUNICATION TERMINAL |
| CN_F_G | EARTH WIRE |
| CN_HP_SW | HIGH PRESSURE SWITCH TERMINAL |

◆FAN PCB NOTE

| SYMBOL | DESCRIPTION |
|-------------|-------------------------------------|
| CN_DCLINK | DC LINK TERMINAL |
| CN_INV | INVERTER PCB COMMUNICATION TERMINAL |
| CN_FAN1_UVW | POWER SUPPLY FOR FAN 1 |
| CN_FAN2_UVW | POWER SUPPLY FOR FAN 2 |
| CN_COMM_OUT | COMMUNICATION TERMINAL |
| CN_LGMV | LGMV MONITORING TERMINAL |
| CN_FLASH | ONBOARDING TERMINAL |

◆INVERTER PCB NOTE

| SYMBOL | DESCRIPTION |
|-----------------|-------------------------------|
| CN_DCLINK_FAN | DC LINK 540 V |
| CN_COMM_IN | COMMUNICATION INPUT TERMINAL |
| CN_COMM_OUT | COMMUNICATION OUTPUT TERMINAL |
| CN_FAN_TSV | DC 15 V OUTPUT TERMINAL |
| CN_AC_IN | AC 220 V INPUT TERMINAL |
| CN_AC_OUT | AC 220 V OUTPUT TERMINAL |
| CN_U | POWER SUPPLY FOR COMP U PHASE |
| CN_V | POWER SUPPLY FOR COMP V PHASE |
| CN_W | POWER SUPPLY FOR COMP W PHASE |
| CN_INPUT_VOLT_T | POWER SUPPLY FOR MAIN T PHASE |
| CN_INPUT_VOLT_S | POWER SUPPLY FOR MAIN S PHASE |
| CN_INPUT_VOLT_R | POWER SUPPLY FOR MAIN R PHASE |

◆EXTERNAL PCB NOTE

| SYMBOL | DESCRIPTION |
|---------|--|
| CN20_BK | MAIN PCB COMMUNICATION TERMINAL |
| CN10_WH | AC POWER 220 V INPUT TERMINAL |
| CN14_BK | FAN(FAN4) |
| CN16_VI | HOT GAS 2 |
| CN18_WH | HOT GAS 1 |
| CN20_GR | FAN(FAN3) |
| CN22_YL | FAN(FAN2) |
| CN23_GY | FAN(FAN1) |
| CN31_WH | HIGH PRESSURE SENSOR 1 |
| CN32_BK | LOW PRESSURE SENSOR 1 |
| CN33_BK | HIGH PRESSURE SENSOR 2 |
| CN34_RD | LOW PRESSURE SENSOR 2 |
| CN35_BK | LIQUID PIPE THERMISTOR(INLET OUTLET) |
| CN36_BK | THERMISTOR(SUCTON1; LIQUID; DISCHARGE1) |
| CN37_YL | THERMISTOR(SUCTON2; LIQUID; DISCHARGE2) |
| CN38_VI | THERMISTOR(SC IN; SC OUT1; HEX1) |
| CN39_BK | THERMISTOR(SC IN; SC OUT2; HEX2) |
| CN40_RD | MAIN ELECTRONIC EXPANSION VALVE 1 |
| CN41_WH | MAIN ELECTRONIC EXPANSION VALVE 2 |
| CN42_BK | SUB-COOLING ELECTRONIC EXPANSION VALVE 1 |
| CN43_GY | SUB-COOLING ELECTRONIC EXPANSION VALVE 2 |
| CN47_WH | MAIN PCB COMMUNICATION TERMINAL |
| CN48_TB | TERMINAL BLOCK |
| CN_F_G | EARTH WIRE |

◆NOISE FILTER NOTE

| SYMBOL | DESCRIPTION |
|------------------|-------------------------------|
| CN1 | AC POWER 220 V |
| CN_IN_R, S, T, N | POWER INPUT TERMINAL |
| CN_OUT_R, S, T | INV PCB POWER OUTPUT TERMINAL |
| CN_F_G | EARTH WIRE |

◆COLOR

| SYMBOL | DESCRIPTION | SYMBOL | DESCRIPTION |
|--------|-------------|---------|-------------|
| RD | RED | VI | VIOLET |
| BL | BLUE | GY | GRAY |
| WH | WHITE | OR | ORANGE |
| BK | BLACK | GN / GR | GREEN |
| BR | BROWN | YL | YELLOW |

Note
1. - - - - - FILED WIRING
2. - - - - - FACTORY WIRING

MEZ67329413 (REV02)

1 Unit, 2 Unit(Main), 3 Unit(Main)

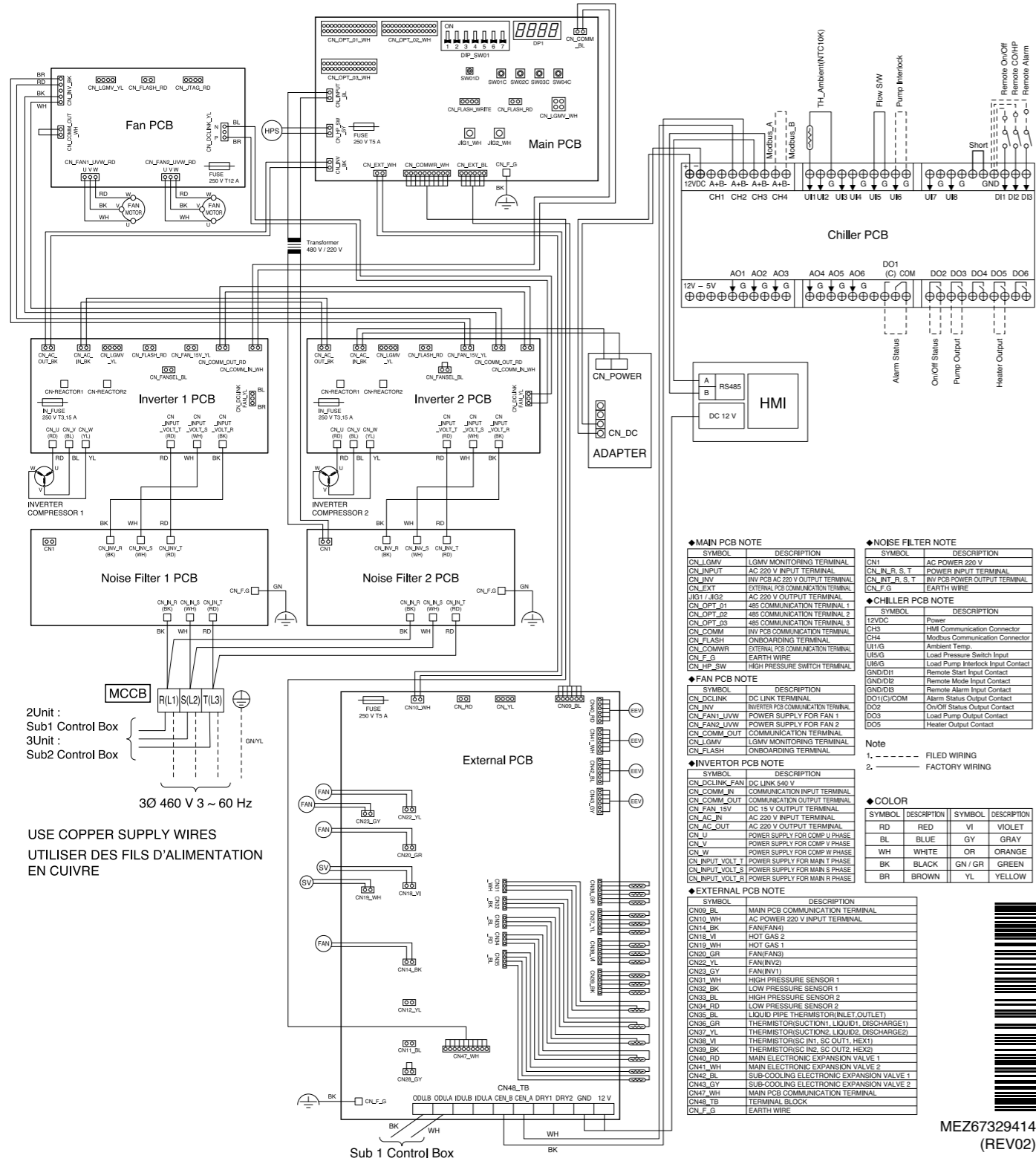

◆MAIN PCB NOTE

| SYMBOL | DESCRIPTION |
|-----------|-------------------------------------|
| CN_LGMV | LGMV MONITORING TERMINAL |
| CN_INPU | AC 220 V INPUT TERMINAL |
| CN_INVN | INV PCB AC 220 V OUTPUT TERMINAL |
| CN_EXT | EXTERNAL PCB COMMUNICATION TERMINAL |
| JIG1/JIG2 | AC 220 V OUTPUT TERMINAL |
| CN_OPT_01 | 485 COMMUNICATION TERMINAL 1 |
| CN_OPT_02 | 485 COMMUNICATION TERMINAL 2 |
| CN_OPT_03 | 485 COMMUNICATION TERMINAL 3 |
| CN_COMM | INV PCB COMMUNICATION TERMINAL |
| CN_FLASH | ONBOARDING TERMINAL |
| CN_COMMWR | EXTERNAL PCB COMMUNICATION TERMINAL |
| CN_F_G | EARTH WIRE |
| CN_HP_SW | HIGH PRESSURE SWITCH TERMINAL |

◆FAN PCB NOTE

| SYMBOL | DESCRIPTION |
|-------------|-------------------------------------|
| CN_DCLINK | DC LINK TERMINAL |
| CN_INVN | INVERTER PCB COMMUNICATION TERMINAL |
| CN_FAN1_UVW | POWER SUPPLY FOR FAN 1 |
| CN_FAN2_UVW | POWER SUPPLY FOR FAN 2 |
| CN_COMM_OUT | COMMUNICATION TERMINAL |
| CN_FLASH | ONBOARDING TERMINAL |

◆INVERTOR PCB NOTE

| SYMBOL | DESCRIPTION |
|-----------------|-------------------------------|
| CN_DCLINK_FAN | DC LINK 540 V |
| CN_COMM_IN | COMMUNICATION INPUT TERMINAL |
| CN_COMM_OUT | COMMUNICATION OUTPUT TERMINAL |
| CN_FAN_15V | DC 15 V OUTPUT TERMINAL |
| CN_AC_IN | AC 220 V INPUT TERMINAL |
| CN_AC_OUT | AC 220 V OUTPUT TERMINAL |
| CN_U | POWER SUPPLY FOR COMP U PHASE |
| CN_V | POWER SUPPLY FOR COMP V PHASE |
| CN_W | POWER SUPPLY FOR COMP W PHASE |
| CN_INPUT_VOLT_T | POWER SUPPLY FOR MAIN T PHASE |
| CN_INPUT_VOLT_S | POWER SUPPLY FOR MAIN S PHASE |
| CN_INPUT_VOLT_R | POWER SUPPLY FOR MAIN R PHASE |

◆EXTERNAL PCB NOTE

| SYMBOL | DESCRIPTION |
|---------|--|
| CN09_BK | MAIN PCB COMMUNICATION TERMINAL |
| CN10_WH | AC POWER 220 V INPUT TERMINAL |
| CN14_BK | FAN(FAN4) |
| CN18_VI | HOT GAS 2 |
| CN18_WH | HOT GAS 1 |
| CN20_GR | FAN(FAN3) |
| CN22_YL | FAN(FAN2) |
| CN23_GY | FAN(FAN1) |
| CN32_GY | HIGH PRESSURE SENSOR 1 |
| CN32_BK | LOW PRESSURE SENSOR 1 |
| CN33_BK | HIGH PRESSURE SENSOR 2 |
| CN33_GY | LOW PRESSURE SENSOR 2 |
| CN34_RD | LIQUID PIPE THERMISTOR(INLET,OUTLET) |
| CN36_GR | THERMISTOR(SUCTON1, LIQUID, DISCHARGE1) |
| CN37_VI | THERMISTOR(SUCTON2, LIQUID, DISCHARGE2) |
| CN38_VI | THERMISTOR(SC IN1, SC OUT1, HEX1) |
| CN38_BK | THERMISTOR(SC IN2, SC OUT2, HEX2) |
| CN39_RD | MAIN ELECTRONIC EXPANSION VALVE 1 |
| CN41_WH | MAIN ELECTRONIC EXPANSION VALVE 2 |
| CN42_BK | SUB-COOLING ELECTRONIC EXPANSION VALVE 1 |
| CN43_GY | SUB-COOLING ELECTRONIC EXPANSION VALVE 2 |
| CN47_WH | MAIN PCB COMMUNICATION TERMINAL |
| CN48_TB | TERMINAL BLOCK |
| CN_F_G | EARTH WIRE |

◆NOISE FILTER NOTE

| SYMBOL | DESCRIPTION |
|------------------|-------------------------------|
| CN1 | AC POWER 220 V |
| CN_R, L, R, S, T | POWER INPUT TERMINAL |
| CN_INT, R, S, T | INV PCB POWER OUTPUT TERMINAL |
| CN_F_G | EARTH WIRE |

◆CHILLER PCB NOTE

| SYMBOL | DESCRIPTION |
|-----------|-----------------------------------|
| 12VDC | Power |
| CH4 | HMI Communication Connector |
| CH5 | Modbus Communication Connector |
| U11G | Ambient Temp. |
| U15G | Load Pressure Switch Input |
| U16G | Load Pump Interlock Input Contact |
| GN(DI1) | Remote Start Input Contact |
| GN(DI2) | Remote Alarm Input Contact |
| DO1(C)COM | Alarm Status Output Contact |
| DO2 | On/Off Status Output Contact |
| DO3 | Load Pump Output Contact |
| DO5 | Heater Output Contact |

◆COLOR

| SYMBOL | DESCRIPTION | SYMBOL | DESCRIPTION |
|--------|-------------|---------|-------------|
| RD | RED | VI | VIOLET |
| BL | BLUE | GY | GRAY |
| WH | WHITE | OR | ORANGE |
| BK | BLACK | GN / GR | GREEN |
| BR | BROWN | YL | YELLOW |

Note
 1. - - - - - FILED WIRING
 2. - - - - - FACTORY WIRING

2 Unit(Sub), 3 Unit(Sub2)

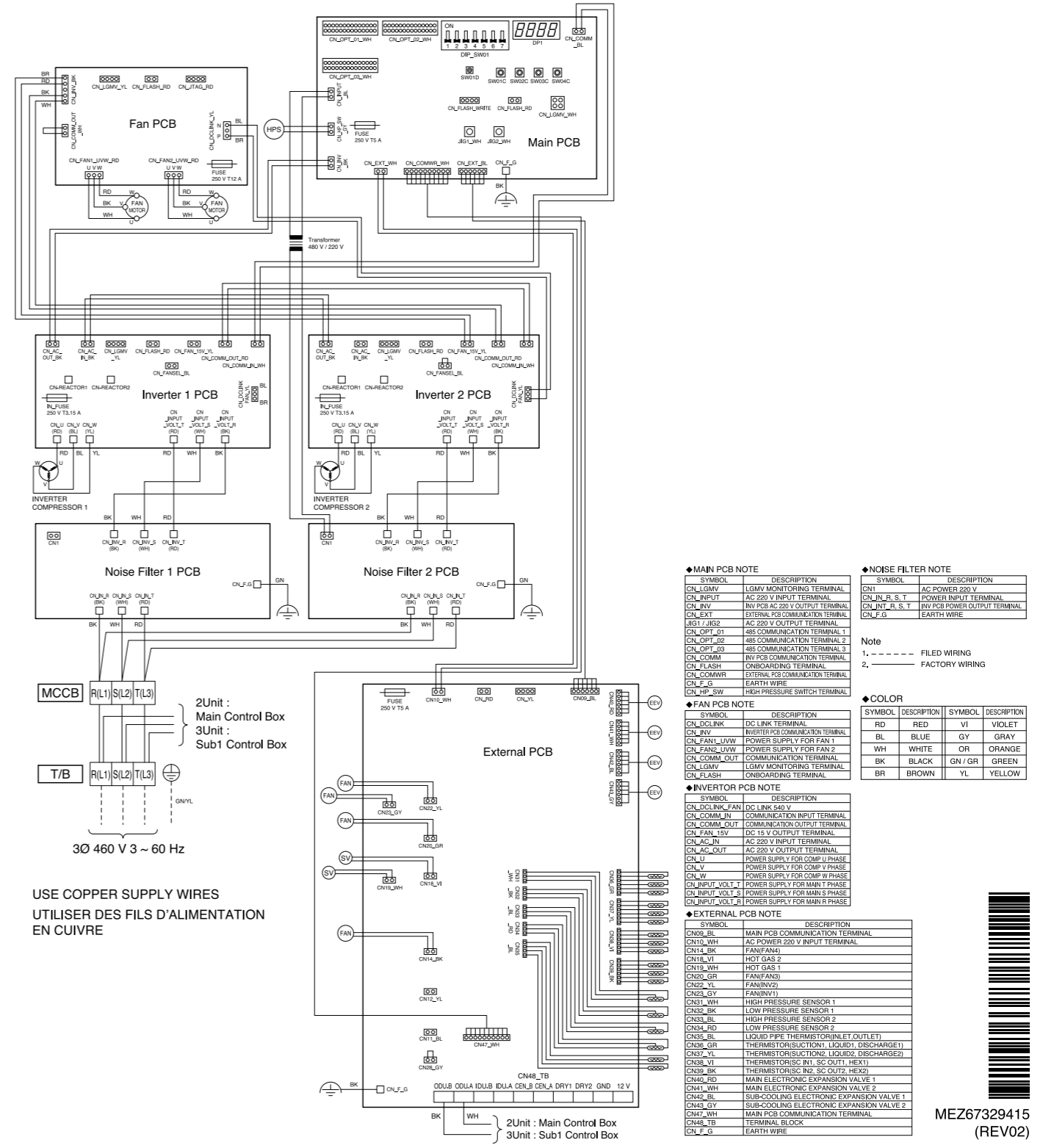

◆MAIN PCB NOTE

| SYMBOL | DESCRIPTION |
|-----------|-------------------------------------|
| CN_LGMV | LGMV MONITORING TERMINAL |
| CN_INPU | AC 220 V INPUT TERMINAL |
| CN_INVN | INV PCB AC 220 V OUTPUT TERMINAL |
| CN_EXT | EXTERNAL PCB COMMUNICATION TERMINAL |
| JIG1/JIG2 | AC 220 V OUTPUT TERMINAL |
| CN_OPT_01 | 485 COMMUNICATION TERMINAL 1 |
| CN_OPT_02 | 485 COMMUNICATION TERMINAL 2 |
| CN_OPT_03 | 485 COMMUNICATION TERMINAL 3 |
| CN_COMM | INV PCB COMMUNICATION TERMINAL |
| CN_FLASH | ONBOARDING TERMINAL |
| CN_COMMWR | EXTERNAL PCB COMMUNICATION TERMINAL |
| CN_F_G | EARTH WIRE |
| CN_HP_SW | HIGH PRESSURE SWITCH TERMINAL |

◆FAN PCB NOTE

| SYMBOL | DESCRIPTION |
|-------------|-------------------------------------|
| CN_DCLINK | DC LINK TERMINAL |
| CN_INVN | INVERTER PCB COMMUNICATION TERMINAL |
| CN_FAN1_UVW | POWER SUPPLY FOR FAN 1 |
| CN_FAN2_UVW | POWER SUPPLY FOR FAN 2 |
| CN_COMM_OUT | COMMUNICATION TERMINAL |
| CN_FLASH | ONBOARDING TERMINAL |

◆INVERTOR PCB NOTE

| SYMBOL | DESCRIPTION |
|-----------------|-------------------------------|
| CN_DCLINK_FAN | DC LINK 540 V |
| CN_COMM_IN | COMMUNICATION INPUT TERMINAL |
| CN_COMM_OUT | COMMUNICATION OUTPUT TERMINAL |
| CN_FAN_15V | DC 15 V OUTPUT TERMINAL |
| CN_AC_IN | AC 220 V INPUT TERMINAL |
| CN_AC_OUT | AC 220 V OUTPUT TERMINAL |
| CN_U | POWER SUPPLY FOR COMP U PHASE |
| CN_V | POWER SUPPLY FOR COMP V PHASE |
| CN_W | POWER SUPPLY FOR COMP W PHASE |
| CN_INPUT_VOLT_T | POWER SUPPLY FOR MAIN T PHASE |
| CN_INPUT_VOLT_S | POWER SUPPLY FOR MAIN S PHASE |
| CN_INPUT_VOLT_R | POWER SUPPLY FOR MAIN R PHASE |

◆EXTERNAL PCB NOTE

| SYMBOL | DESCRIPTION |
|---------|--|
| CN09_BK | MAIN PCB COMMUNICATION TERMINAL |
| CN10_WH | AC POWER 220 V INPUT TERMINAL |
| CN14_BK | FAN(FAN4) |
| CN18_VI | HOT GAS 2 |
| CN18_WH | HOT GAS 1 |
| CN20_GR | FAN(FAN3) |
| CN22_YL | FAN(FAN2) |
| CN23_GY | FAN(FAN1) |
| CN32_GY | HIGH PRESSURE SENSOR 1 |
| CN32_BK | LOW PRESSURE SENSOR 1 |
| CN33_BK | HIGH PRESSURE SENSOR 2 |
| CN33_GY | LOW PRESSURE SENSOR 2 |
| CN34_RD | LIQUID PIPE THERMISTOR(INLET,OUTLET) |
| CN36_GR | THERMISTOR(SUCTON1, LIQUID, DISCHARGE1) |
| CN37_VI | THERMISTOR(SUCTON2, LIQUID, DISCHARGE2) |
| CN38_VI | THERMISTOR(SC IN1, SC OUT1, HEX1) |
| CN38_BK | THERMISTOR(SC IN2, SC OUT2, HEX2) |
| CN39_RD | MAIN ELECTRONIC EXPANSION VALVE 1 |
| CN41_WH | MAIN ELECTRONIC EXPANSION VALVE 2 |
| CN42_BK | SUB-COOLING ELECTRONIC EXPANSION VALVE 1 |
| CN43_GY | SUB-COOLING ELECTRONIC EXPANSION VALVE 2 |
| CN47_WH | MAIN PCB COMMUNICATION TERMINAL |
| CN48_TB | TERMINAL BLOCK |
| CN_F_G | EARTH WIRE |

◆NOISE FILTER NOTE

| SYMBOL | DESCRIPTION |
|------------------|-------------------------------|
| CN1 | AC POWER 220 V |
| CN_R, L, R, S, T | POWER INPUT TERMINAL |
| CN_INT, R, S, T | INV PCB POWER OUTPUT TERMINAL |
| CN_F_G | EARTH WIRE |

◆COLOR

| SYMBOL | DESCRIPTION | SYMBOL | DESCRIPTION |
|--------|-------------|---------|-------------|
| RD | RED | VI | VIOLET |
| BL | BLUE | GY | GRAY |
| WH | WHITE | OR | ORANGE |
| BK | BLACK | GN / GR | GREEN |
| BR | BROWN | YL | YELLOW |

Note
 1. - - - - - FILED WIRING
 2. - - - - - FACTORY WIRING

3 Unit(Sub1)

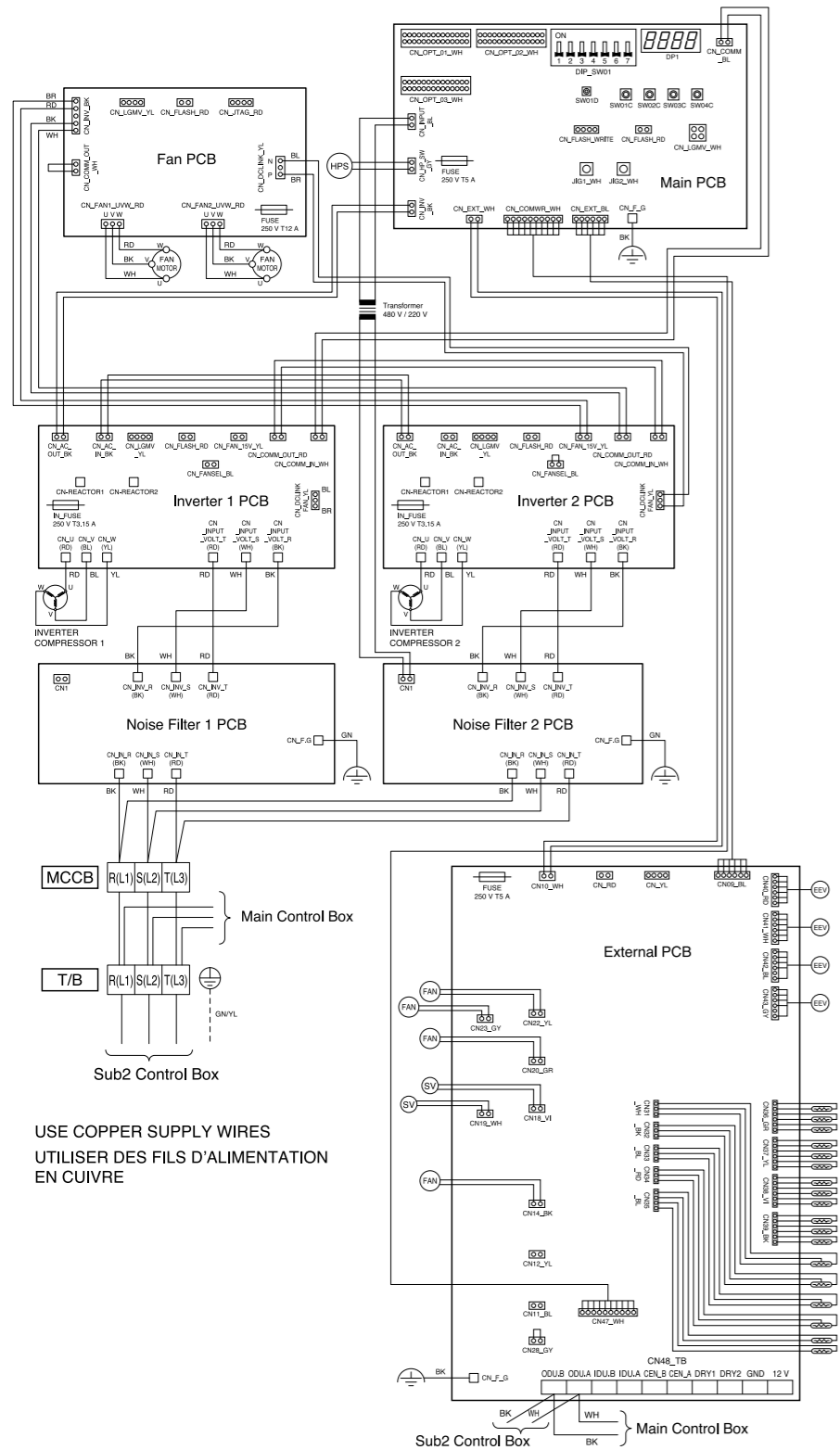

◆MAIN PCB NOTE

| SYMBOL | DESCRIPTION |
|-----------|-------------------------------------|
| CN_LGMV | LGMV MONITORING TERMINAL |
| CN_INPU | AC 220 V INPUT TERMINAL |
| CN_INV | INV PCB AC 220 V OUTPUT TERMINAL |
| CN_EXT | EXTERNAL PCB COMMUNICATION TERMINAL |
| CN_OPT_01 | AC 220 V OUTPUT TERMINAL 1 |
| CN_OPT_02 | 485 COMMUNICATION TERMINAL 2 |
| CN_OPT_03 | 485 COMMUNICATION TERMINAL 3 |
| CN_COMM | INV PCB COMMUNICATION TERMINAL |
| CN_FLASH | ONBOARDING TERMINAL |
| CN_COMMWR | EXTERNAL PCB COMMUNICATION TERMINAL |
| CN_F_SW | EARTH WIRE |
| CN_HP_SW | HIGH PRESSURE SWITCH TERMINAL |

◆FAN PCB NOTE

| SYMBOL | DESCRIPTION |
|--------------|--------------------------|
| CN_DLINK | DC LINK TERMINAL |
| CN_FAN1_LVWV | POWER SUPPLY FOR FAN 1 |
| CN_FAN2_LVWV | POWER SUPPLY FOR FAN 2 |
| CN_COMM_OUT | COMMUNICATION TERMINAL |
| CN_LGMV | LGMV MONITORING TERMINAL |
| CN_FLASH | ONBOARDING TERMINAL |

◆INVERTOR PCB NOTE

| SYMBOL | DESCRIPTION |
|----------------|-------------------------------|
| CN_DLINK_FAN | DC LINK 540 V |
| CN_COMM_IN | COMMUNICATION INPUT TERMINAL |
| CN_COMM_OUT | COMMUNICATION OUTPUT TERMINAL |
| CN_FAN1_LVWV | DC 15V OUTPUT TERMINAL |
| CN_AC_OUT | AC 220V OUTPUT TERMINAL |
| CN_U | POWER SUPPLY FOR COMP U PHASE |
| CN_V | POWER SUPPLY FOR COMP V PHASE |
| CN_W | POWER SUPPLY FOR COMP W PHASE |
| CN_INPU_VOLT_U | POWER SUPPLY FOR MAIN U PHASE |
| CN_INPU_VOLT_V | POWER SUPPLY FOR MAIN V PHASE |
| CN_INPU_VOLT_W | POWER SUPPLY FOR MAIN W PHASE |

◆EXTERNAL PCB NOTE

| SYMBOL | DESCRIPTION |
|---------|--|
| CN20_BR | MAIN PCB COMMUNICATION TERMINAL |
| CN10_WH | AC POWER 220 V INPUT TERMINAL |
| CN14_BK | FAN(FAN4) |
| CN16_VI | HOT GAS 2 |
| CN18_WH | HOT GAS 1 |
| CN20_GR | FAN(FAN3) |
| CN22_YL | FAN(FAN2) |
| CN24_GY | FAN(FAN1) |
| CN31_WH | HIGH PRESSURE SENSOR 1 |
| CN32_BK | LOW PRESSURE SENSOR 1 |
| CN33_BR | HIGH PRESSURE SENSOR 2 |
| CN34_RD | LOW PRESSURE SENSOR 2 |
| CN35_BR | LIQUID PIPE THERMISTOR(INLET OUTLET) |
| CN36_BR | THERMISTOR(SUCTION1, LIQUID, DISCHARGE1) |
| CN37_YL | THERMISTOR(SUCTION2, LIQUID, DISCHARGE2) |
| CN38_VI | THERMISTOR(SC IN), SC OUT1, HEX1) |
| CN39_BK | THERMISTOR(SC IN), SC OUT2, HEX2) |
| CN40_RD | MAIN ELECTRONIC EXPANSION VALVE 1 |
| CN41_WH | MAIN ELECTRONIC EXPANSION VALVE 2 |
| CN42_BR | SUB-COOLING ELECTRONIC EXPANSION VALVE 1 |
| CN43_GY | SUB-COOLING ELECTRONIC EXPANSION VALVE 2 |
| CN44_CR | VAPOR INJECTION ELECTRONIC EXPANSION VALVE 1 |
| CN45_BR | VAPOR INJECTION ELECTRONIC EXPANSION VALVE 2 |
| CN47_WH | MAIN PCB COMMUNICATION TERMINAL |
| CN48_TB | TERMINAL BLOCK |
| CN_F_G | EARTH WIRE |

◆NOISE FILTER NOTE

| SYMBOL | DESCRIPTION |
|----------------|-------------------------------|
| CN1 | AC POWER 220 V |
| CN_IN_R, S, T | POWER INPUT TERMINAL |
| CN_OUT_R, S, T | INV PCB POWER OUTPUT TERMINAL |
| CN_F_G | EARTH WIRE |

Note
1, - - - - - FILED WIRING
2, - - - - - FACTORY WIRING

◆COLOR

| SYMBOL | DESCRIPTION | SYMBOL | DESCRIPTION |
|--------|-------------|---------|-------------|
| RD | RED | VI | VIOLET |
| BL | BLUE | GR | GRAY |
| WH | WHITE | OR | ORANGE |
| BK | BLACK | GN / GR | GREEN |
| BR | BROWN | YL | YELLOW |

MEZ67329416
(REV02)

1 Unit, 2 Unit(Main)

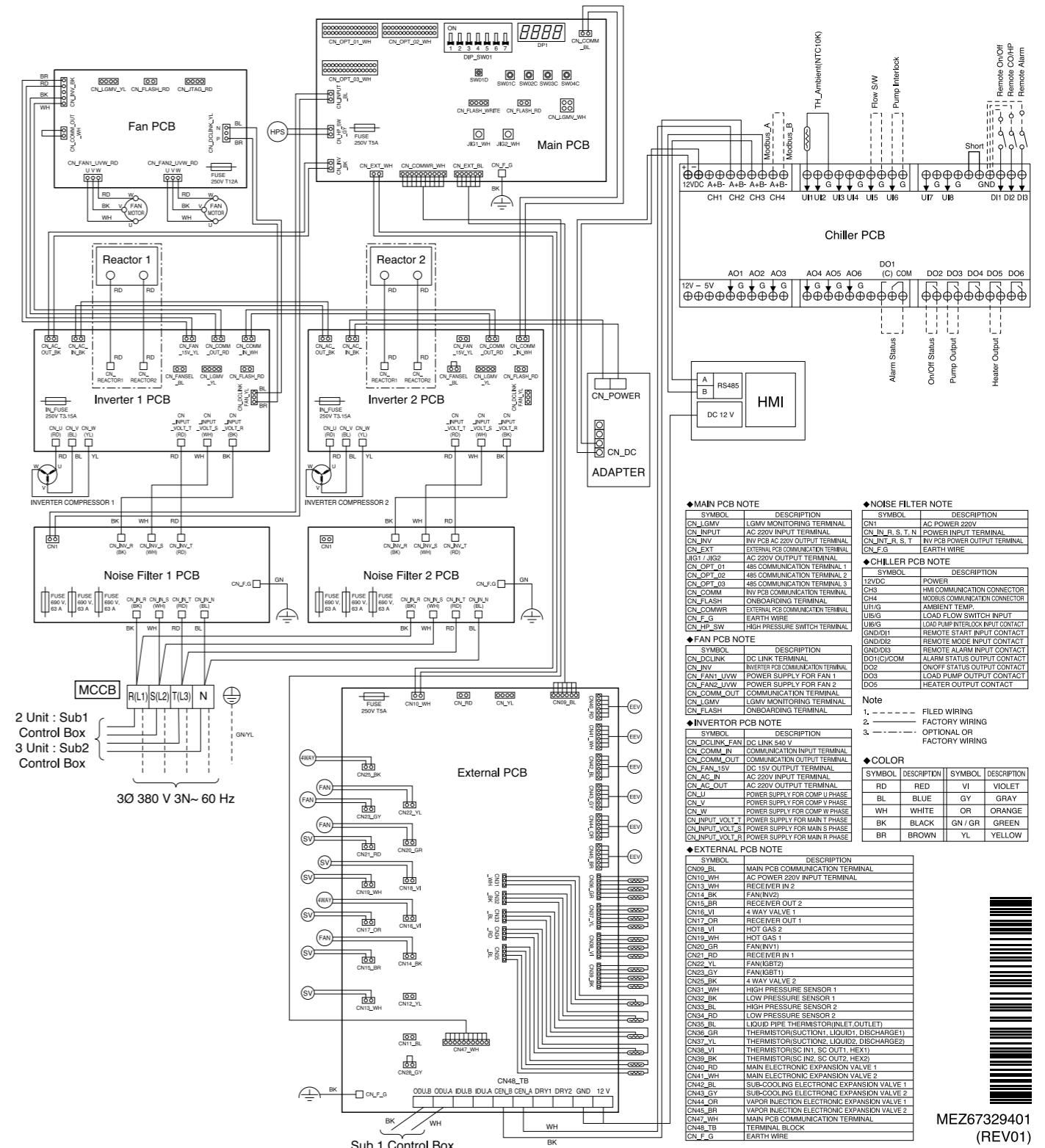

◆MAIN PCB NOTE

| SYMBOL | DESCRIPTION |
|-----------|-------------------------------------|
| CN_LGMV | LGMV MONITORING TERMINAL |
| CN_INPU | AC 220 V INPUT TERMINAL |
| CN_INV | INV PCB AC 220 V OUTPUT TERMINAL |
| CN_EXT | EXTERNAL PCB COMMUNICATION TERMINAL |
| CN_OPT_01 | AC 220 V OUTPUT TERMINAL |
| CN_OPT_02 | 485 COMMUNICATION TERMINAL 1 |
| CN_OPT_03 | 485 COMMUNICATION TERMINAL 2 |
| CN_COMM | INV PCB COMMUNICATION TERMINAL |
| CN_FLASH | ONBOARDING TERMINAL |
| CN_COMMWR | EXTERNAL PCB COMMUNICATION TERMINAL |
| CN_F_SW | EARTH WIRE |
| CN_HP_SW | HIGH PRESSURE SWITCH TERMINAL |

◆FAN PCB NOTE

| SYMBOL | DESCRIPTION |
|--------------|-------------------------------------|
| CN_DLINK | DC LINK TERMINAL |
| CN_INV | INVERTOR PCB COMMUNICATION TERMINAL |
| CN_FAN1_LVWV | POWER SUPPLY FOR FAN 1 |
| CN_FAN2_LVWV | POWER SUPPLY FOR FAN 2 |
| CN_COMM_OUT | COMMUNICATION TERMINAL |
| CN_LGMV | LGMV MONITORING TERMINAL |
| CN_FLASH | ONBOARDING TERMINAL |

◆INVERTOR PCB NOTE

| SYMBOL | DESCRIPTION |
|----------------|-------------------------------|
| CN_DLINK_FAN | DC LINK 540 V |
| CN_COMM_IN | COMMUNICATION INPUT TERMINAL |
| CN_COMM_OUT | COMMUNICATION OUTPUT TERMINAL |
| CN_FAN1_LVWV | DC 15V OUTPUT TERMINAL |
| CN_AC_OUT | AC 220V OUTPUT TERMINAL |
| CN_U | POWER SUPPLY FOR COMP U PHASE |
| CN_V | POWER SUPPLY FOR COMP V PHASE |
| CN_W | POWER SUPPLY FOR COMP W PHASE |
| CN_INPU_VOLT_U | POWER SUPPLY FOR MAIN U PHASE |
| CN_INPU_VOLT_V | POWER SUPPLY FOR MAIN V PHASE |
| CN_INPU_VOLT_W | POWER SUPPLY FOR MAIN W PHASE |

◆EXTERNAL PCB NOTE

| SYMBOL | DESCRIPTION |
|---------|--|
| CN09_BR | MAIN PCB COMMUNICATION TERMINAL |
| CN10_WH | AC POWER 220 V INPUT TERMINAL |
| CN13_WH | RECEIVER IN 2 |
| CN14_BK | FAN(FAN2) |
| CN15_BR | RECEIVER OUT 2 |
| CN18_VI | 4 WAY VALVE 1 |
| CN17_OR | RECEIVER OUT 1 |
| CN18_VI | HOT GAS 2 |
| CN19_WH | HOT GAS 1 |
| CN20_GR | FAN(FAN1) |
| CN21_RD | RECEIVER IN 1 |
| CN22_YL | FAN(FAN3) |
| CN23_GY | FAN(FAN4) |
| CN25_BK | 4 WAY VALVE 2 |
| CN31_WH | HIGH PRESSURE SENSOR 1 |
| CN32_BK | LOW PRESSURE SENSOR 1 |
| CN33_BR | HIGH PRESSURE SENSOR 2 |
| CN34_RD | LOW PRESSURE SENSOR 2 |
| CN35_BR | LIQUID PIPE THERMISTOR(INLET OUTLET) |
| CN36_BR | THERMISTOR(SUCTION1, LIQUID, DISCHARGE1) |
| CN37_YL | THERMISTOR(SUCTION2, LIQUID, DISCHARGE2) |
| CN38_VI | THERMISTOR(SC IN), SC OUT1, HEX1) |
| CN39_BK | THERMISTOR(SC IN), SC OUT2, HEX2) |
| CN40_RD | MAIN ELECTRONIC EXPANSION VALVE 1 |
| CN41_WH | MAIN ELECTRONIC EXPANSION VALVE 2 |
| CN42_BR | SUB-COOLING ELECTRONIC EXPANSION VALVE 1 |
| CN43_GY | SUB-COOLING ELECTRONIC EXPANSION VALVE 2 |
| CN44_CR | VAPOR INJECTION ELECTRONIC EXPANSION VALVE 1 |
| CN45_BR | VAPOR INJECTION ELECTRONIC EXPANSION VALVE 2 |
| CN47_WH | MAIN PCB COMMUNICATION TERMINAL |
| CN48_TB | TERMINAL BLOCK |
| CN_F_G | EARTH WIRE |

◆NOISE FILTER NOTE

| SYMBOL | DESCRIPTION |
|----------------|-------------------------------|
| CN1 | AC POWER 220V |
| CN_IN_R, S, T | POWER INPUT TERMINAL |
| CN_OUT_R, S, T | INV PCB POWER OUTPUT TERMINAL |
| CN_F_G | EARTH WIRE |

◆CHILLER PCB NOTE

| SYMBOL | DESCRIPTION |
|--------|-----------------------------------|
| CH3 | POWER |
| CH4 | HMI COMMUNICATION CONNECTOR |
| CH5 | MODBUS COMMUNICATION CONNECTOR |
| UT1G | AMBIENT TEMP |
| UB1G | LOAD FLOW SWITCH INPUT |
| UB1S | LOAD PUMP INTERLOCK INPUT CONTACT |
| UB2 | REMOTE START INPUT CONTACT |
| UB2D1 | REMOTE MODE INPUT CONTACT |
| UB2D2 | REMOTE ALARM INPUT CONTACT |
| UB2D3 | ALARM STATUS OUTPUT CONTACT |
| UB2D4 | ON/OFF STATUS OUTPUT CONTACT |
| UB2D5 | LOAD PUMP OUTPUT CONTACT |
| UB2D6 | HEATER OUTPUT CONTACT |

Note

1, - - - - - FILED WIRING
2, - - - - - FACTORY WIRING
3, - - - - - OPTIONAL OR FACTORY WIRING

◆COLOR

| SYMBOL | DESCRIPTION | SYMBOL | DESCRIPTION |
|--------|-------------|---------|-------------|
| RD | RED | VI | VIOLET |
| BL | BLUE | GR | GRAY |
| WH | WHITE | OR | ORANGE |
| BK | BLACK | GN / GR | GREEN |
| BR | BROWN | YL | YELLOW |

MEZ67329401
(REV01)

2 Unit(Sub)

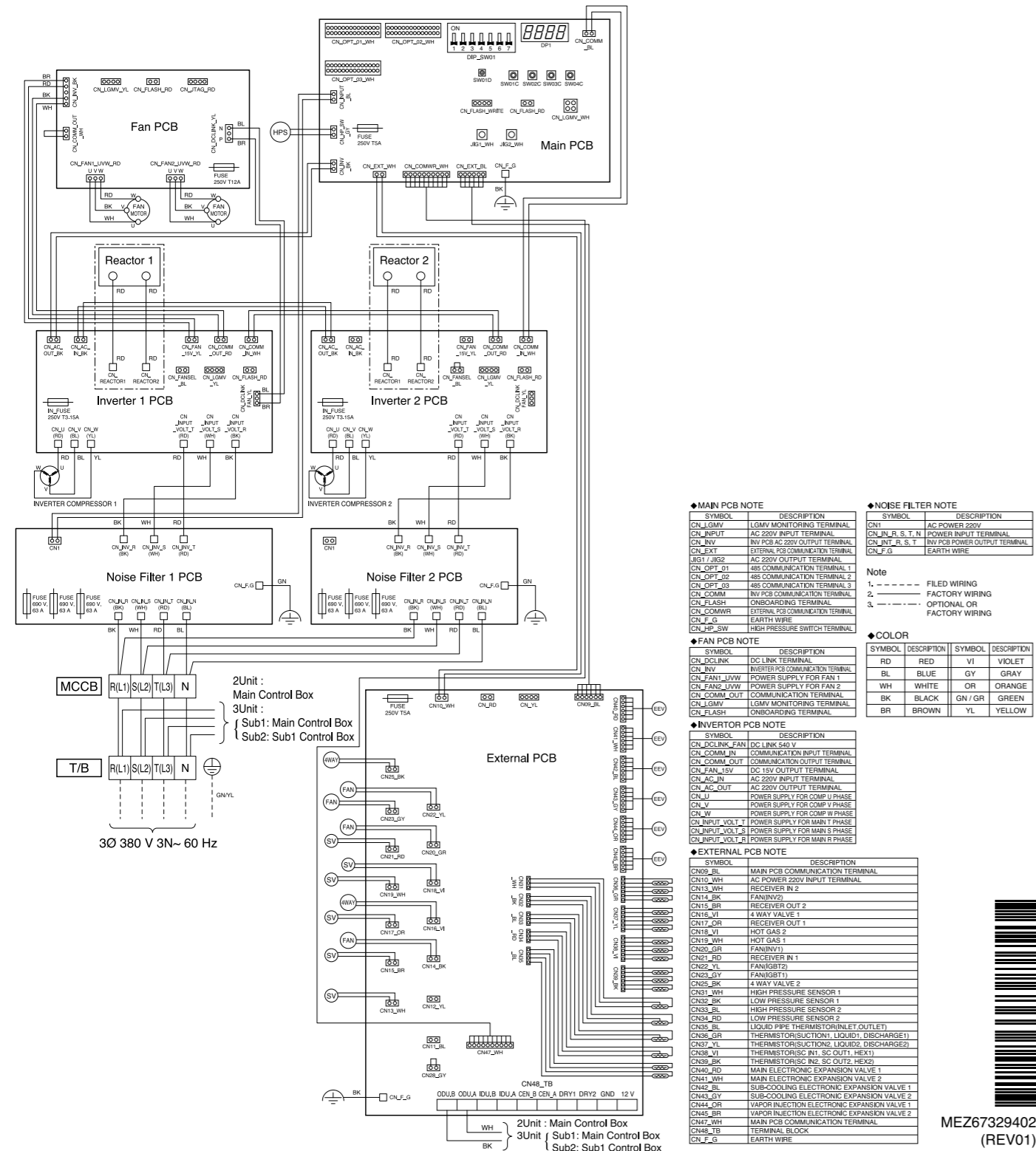

Consider the service space

There must be sufficient space for maintenance and repair work around the chiller.

Because this is the space where the water pipes are installed, make sure to secure sufficient space for future maintenance and repair work.

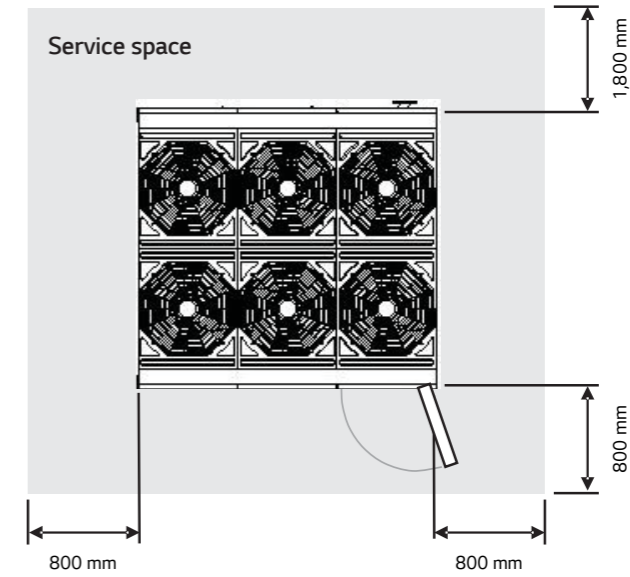

Because this is the space where the water pipes are installed, make sure to secure sufficient space for future maintenance and repair work.

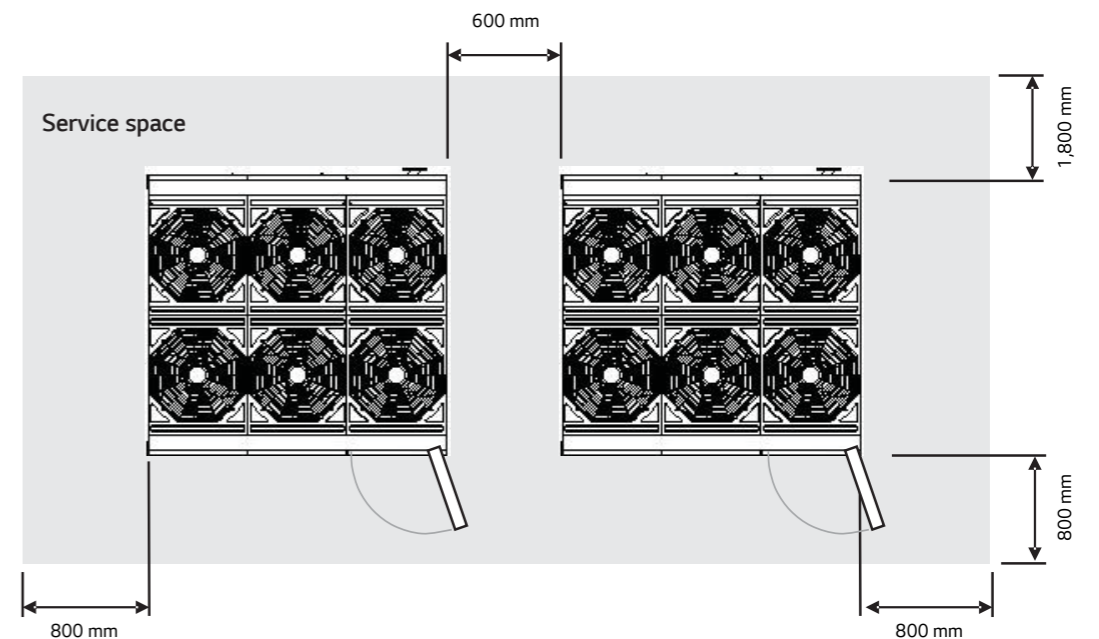

Water management

The water quality of the cold(Hot) water is described as follows. The water quality must not fall below the following standard. If so, it can be judged to have risk within relatively short period of time.

| Item | Water | |
|-----------------------------|-----------------------------|--------------|
| | Circulation type cold water | Cold water |
| PH(25°C) | 6.5 - 8.0 | 6.5 - 8.0 |
| Conduction rate(25°C μs/cm) | 500 or below | 200 or below |
| Alkali level(PPM) | 100 or below | 50 or below |
| Hardness(PPM) | 100 or below | 50 or below |
| Chlorine ion(PPM) | 100 or below | 50 or below |
| Lactic acid ion(PPM) | 100 or below | 50 or below |
| Iron(PPM) | 0.1 or below | 0.3 or below |
| Sulfur ion(PPM) | Not detected | Not detected |
| Ammonium ion(PPM) | 0.5 or below | 0.2 or below |
| Silica(PPM) | 50 or below | 30 or below |

Water pipe connection

- Connect the pipe so that the entrance of the cold(Hot) water pipe is correct.
- Permitted water pressure resistance of cold water pipe system is 1MPa
- To prevent any external heat loss or dew drops forming during the cooling operation on the water pipe system, apply thermal insulation treatment.
- Install the air vent at the output end of the water pipe.(Air vent)
- If the thermometer is installed on the inlet/outlet of the cold/hot water pipe, the operating condition of the chiller can be checked.
- Always install the strainer(50 Mesh or above) that can be cleaned on the water pipe inlet side to filter any alien particles from entering the heat exchanger.
- Always install the strainer on the leveled pipe.
(If sand, trash or rust gets mixed to the cold water system, it can cause product failure due to corrosion of metallic parts.)
- Install the on/off valve on the cold water inlet/outlet and bypass pipe on the pipe direction of the device side.
 - For the pipe system, it is recommended to install the bypass and clean the pipe before installing the product and during the annual pipe cleaning.
 - On/Off valve blocks the old water to the chiller that is not operating to reduce the power of the pump.
Therefore select whether to install to fit the need of the site.
- Install the pressure gauge and thermometer on the inlet and outlet of the water pipe.
- Always install the flexible joint to reduce the vibration of the pipe and product.
 - Vibration of water pipe system is absorbed to prevent water leakage.
- For the cold water system part, make sure to use the component that complies with designed water pressure or above.
- Before supplying cold water to the chiller, clean inside the pipe system to remove any negative impact of particles to the product.

Detail of the piping around the pump

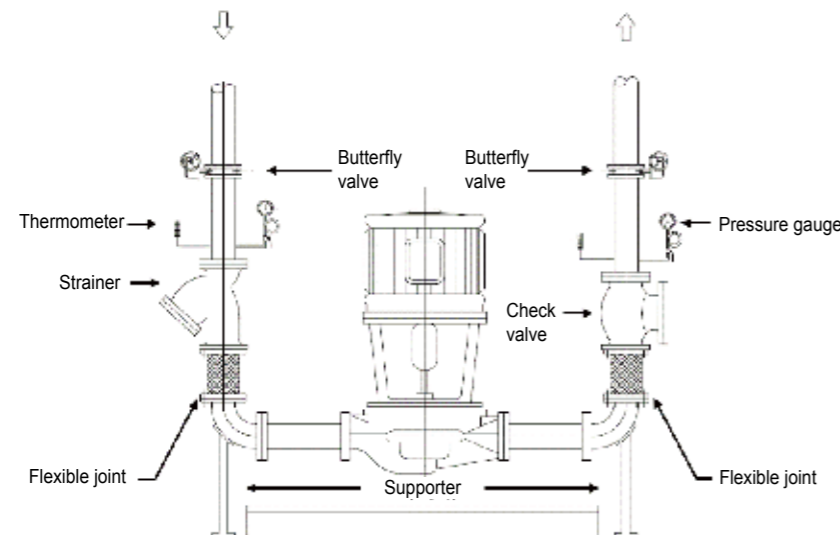

Installation mode A(Recommended method)

• Independent product installation

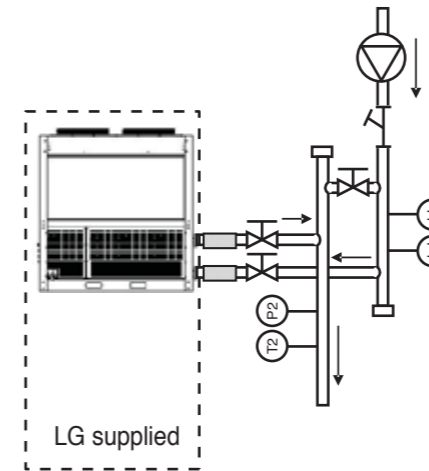

• Independent product installation

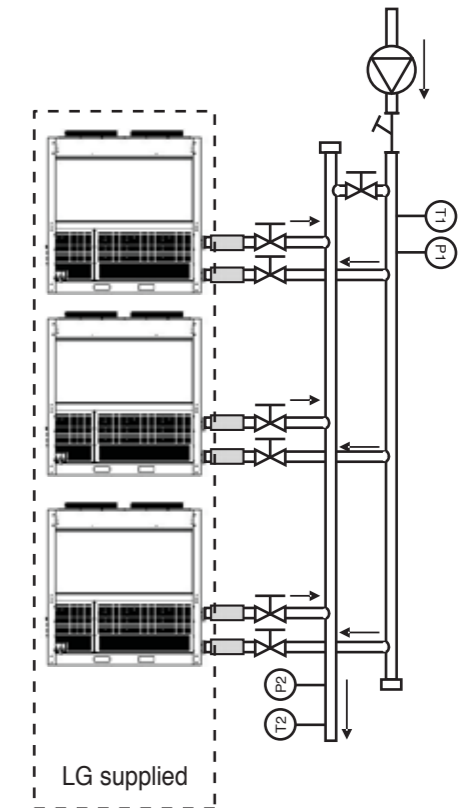

| Symbol | Description |
|--------|----------------|
| | Valve |
| | Strainer |
| | Flexible joint |

| Symbol | Description |
|--------|--|
| T1 | Temperature sensor(1: Inlet 2: Outlet) |
| P1 | Pressure gauge(1: Inlet, 2: Outlet) |
| | Cold water pump |

Installation mode B

• Independent product installation

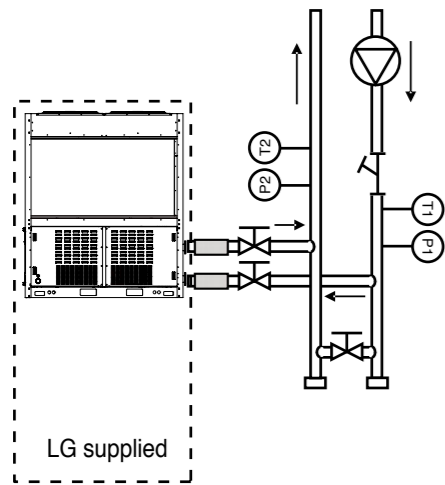

• Independent product installation

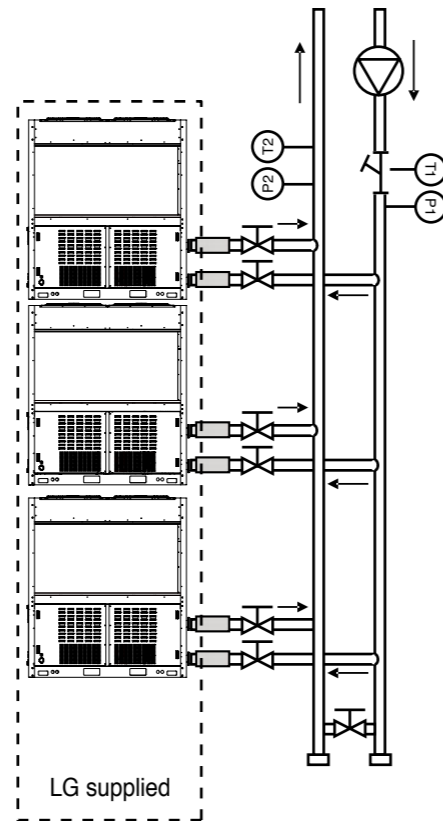

| Symbol | Description |
|--------|----------------|
| | Valve |
| | Strainer |
| | Flexible joint |

| Symbol | Description |
|--------|--|
| T1 | Temperature sensor(1: Inlet 2: Outlet) |
| P1 | Pressure gauge(1: Inlet, 2: Outlet) |
| | Cold water pump |

CAUTION

- If the winter outdoor temperature is 0°C or below, take following measures to prevent the pipe from freezing as shown below.
- If the outdoor temperature is low, the circulation water can freeze to damage the heat exchanger of the product when the product is stopped. If there is possibility of damage from low outdoor temperature, operate the pump to prevent the water from freezing.
- If the product does not operate for a long period of time during the winter season, remove all the circulation water to prevent the damage of heat exchanger and pipe from freezing.
- Add anti-freeze additive to prevent the circulation water from freezing during the winter season.
- Maintain the cold water flux within the designed flux to ensure appropriate chiller performance and reduce the tube damage from rusting, scaling and corrosion. LG is not responsible for any damage of chiller from poor water quality management or inappropriate processing water.

Water pipe installation

- Appropriate pressure of pipe connection is flange connection of 1 MPa or below.
- Size of the water pipe must be the same as that of the product or larger.
- If there is risk of dew drops forming, always install the thermal insulation material on the outlet pipe of the cold water.
- To avoid connected water pipe from creeping from the load, use appropriate hook for support.
- To prevent the pipe connected part from freezing during the winter season, always install the drain valve at the most bottom of the pipe system.
- Cold water inlet pipe is located at the bottom and the outlet pipe is installed on the top.
- When connecting several chillers, refer to the following for common pipe size.

ACAH Series

| Full product capacity | 20 RT | 40 RT | 60 RT | 80 RT | 100 RT | 120 RT | 140 RT |
|-----------------------|-------|-------|-------|-------|--------|--------|--------|
| Common pipe size | 65 A | 80 A | 100 A | 100 A | 125 A | 125 A | 125 A |
| Product | 20 RT | • | | | | | |
| | 40 RT | | • | | •• | • | •• |
| | 60 RT | | | • | | • | •• |

| Full product capacity | 160 RT | 180 RT | 200 RT | 220 RT | 240 RT | 260 RT | 280 RT | 300 RT |
|-----------------------|--------|--------|--------|--------|--------|--------|--------|--------|
| Common pipe size | 150 A | 150 A | 150 A | 200 A | 200 A | 200 A | 200 A | 200 A |
| Product | 20 RT | | | | | | | |
| | 40 RT | • | | •• | • | •• | • | |
| | 60 RT | •• | ••• | •• | ••• | •••• | ••• | •••• |

ACHH Series

| Full product capacity | 20 RT | 40 RT | 60 RT | 80 RT | 100 RT | 120 RT | 140 RT |
|-----------------------|-------|-------|-------|-------|--------|--------|--------|
| Common pipe size | 65 A | 80 A | 100 A | 100 A | 125 A | 125 A | 125 A |
| Product | 20 RT | • | • | • | • | •• | • |
| | 40 RT | | • | • | •• | •• | ••• |

| Full product capacity | 160 RT | 180 RT | 200 RT | 220 RT | 240 RT | 260 RT | 280 RT | 300 RT |
|-----------------------|--------|--------|--------|--------|--------|--------|--------|--------|
| Common pipe size | 150 A | 150 A | 150 A | 200 A | 200 A | 200 A | 200 A | 200 A |
| Product | 20 RT | • | | • | | • | | • |
| | 40 RT | •••• | •••• | ••••• | ••••• | ••••• | ••••• | ••••• |

Water pump control

- If the cold water pump is not operating for a long period of time or if the anti-freeze liquid is not used as the cold water, the anti-freeze pump control must be installed to prevent the pipe from freezing.
- The vibration of the pump can transfer to the pipe to cause noise indoors. As the plan to prevent the noise from spreading in the pump, install flexible joints at the inlet/outlet and use the anti-vibration amount for the pump support.

Unit Combination

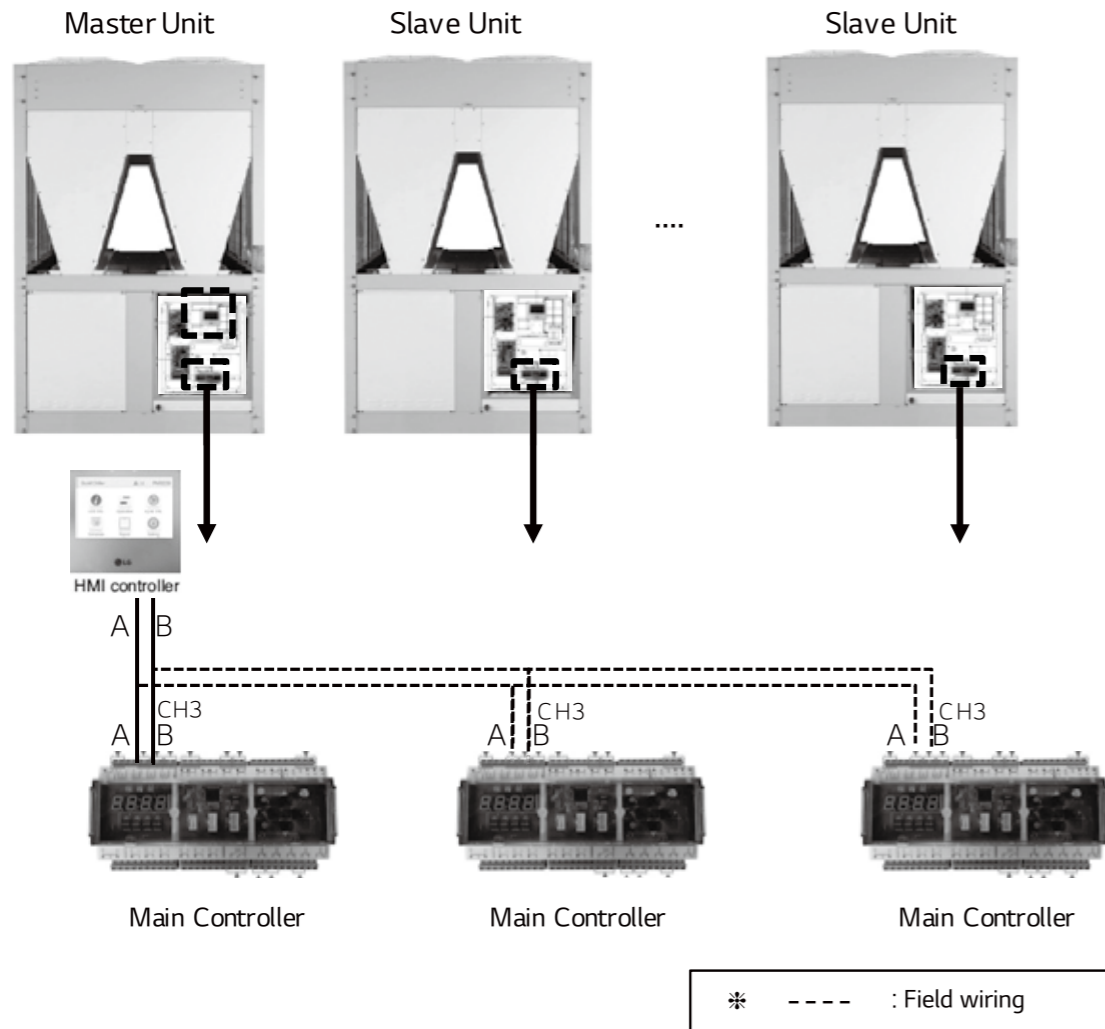

- 1) Communication line is divided A into B like a picture and is jump connected to Main Unit and Main Controller CH3 of Slave unit.
- 2) Communication line jump connected is divided A into B to HMI of Master Unit and in connected.
- 3) Use 2-line shield as a communication line
- 4) Separately install the communication and power cable of the chiller so that communication cable is not affected by the electric noise generated from power cable(Do not pass though the same electric pipe)
- 5) Unit combination is able to connect up to 5 units.

⚠ WARNING

If number and address of product to want to interlock is not set from HMI, Error will occur.(please refer to control>freezer interlocking control about HMI address setting)

If Main Controller address doesn't match HMI address, Error will occur. .(please refer to control>freezer address setting about Controller address setting)

Guide Specification(ACAH Series)

Contents

1. Casing
2. Compressor
3. Condenser
4. Electronic expansion valve
5. Evaporator
6. Control equipment
7. Ref. piping
8. Safety devices

Manufacturing specification

- 1) Use parts and materials of KS standard or equivalent for chillers not specified in this specification, and all parts should be designed with structure that is easy for replacement, repair, and inspection.
- 2) If there is a problem in the chiller, or if there is an abnormal status of chilled water temperature and flow amount, etc., immediately stop the chiller operation and you have to be equipped with certified equipment or function that can easily be identified.
- 3) There should be a protection circuit to prevent chiller damage from blackout or frequent voltage variation from power plant.
- 4) Chiller should be able to operate silently without abnormal noise or abnormal vibration.
- 5) Chiller should be composed of the central controller and the circuit possible for wired/wireless Start/Stop operation.
- 6) Easy combination should be possible with compact and module type design.
- 7) It should be the structure possible for back-up operation even if compressor or some parts fail and cooling operation should be available during parts replacement, repair, or inspection.
- 8) The main power cable with equivalent or above the specification presented in the product specification of each corresponding model should be used for the chiller, each communication line and power cable should use cable pipe for protection, and the cable pipe with the material that can block external electrical noise according to the installation environment should be used.

Air cooled type scroll chiller product specification

1. Casing

- 1) It should have the structure that is easy for disassembly and assembly for easy maintenance/repair.
- 2) It should have a good looking exterior and it should be insulated to prevent condensation.
- 3) It should have the structure preventing vibration and abnormal noise.
- 4) It should have the structure that can be grounded.

2. Compressor

- 1) R410A refrigerant shall be used in compressor whose casing shall be completely sealed hermetic type. Combination of two inverter scroll compressors shall be provided which shall be adjusted for soft loading, and shall be a high efficiency compressing system that can optimize energy consumption by using inverter control.
- 2) Vibration prevention rubber should be used to prevent transferring noise and vibration during operation.
- 3) The frequency variable boundary of inverter scroll compressor

shall be minimum 30Hz and maximum 127Hz.

- 4) Alternating operation should be possible to have the uniform average operation time for each compressor.

3. Condenser

- 1) Condenser heat exchanger shall be used with purity 99.9 % or above Phosphorus Deoxidized Copper without joint, and it shall have the structure with Al fin attached to increase the heating area.(Cross fin & Tube type)
- 2) Use wide louver fin for Al fin, and pipe extension shall be carried out for efficient heat transfer.
- 3) Condenser air cooled type heat exchanger arrangement shall be 3 rows, 48 levels of 14FPI.
- 4) Pressure test for high pressure part in refrigerant side should be carried out at 4.18 MPa or above(Designed pressure 3.8 MPa), and there should not be problems such as leakage or deformation.
- 5) Condensing coil that passed pressure test should be vacuumed to completely remove moisture inside.
- 6) Use propeller type Fans, which should be able to provide sufficient air flow required for cooling. Also, it should have sufficient strength for rotating speed, and should be operated silently through balance test.
- 7) Motor should be BLDC type that can increase efficiency.
- 8) Fan shall be connected directly to driving motor.

4. Electronic Expansion Valve

- 1) It is used at adiabatic-expansion process in refrigeration cycle and expands high pressure fluid refrigerant at condenser exit converting to low temperature / low pressure state, and linear electronic expansion valve shall be activated to adjust refrigerant amount according to evaporator load during cooling operation.
- 2) Based on data from various sensors installed in the chiller, micro-computer shall be able to analyze operation status of the system and compressor shall control the optimum refrigerant amount linearly.
- 3) By applying electric pulse signal to stepping motor, it shall be able to play a role of adjusting refrigerant flow amount.

5. Evaporator

- 1) Evaporator shall be shell & tube type heat exchanger, and the material shall be carbon steel for shell and copper for tubes.
- 2) There should be no water leakage, and the durability should be guaranteed.
- 3) It should have the structure that can connect to chilled water pipe.
- 4) Heat exchanger should be robust structure not allowing that the refrigerant and coolant are not mixed.
- 5) It shall be a DX type heat exchanger that refrigerant flows inside tubes and water flows inside shell. Chemical cleaning should be conducted periodically for protective

maintenance of chillers.

- 6) As a standard, the evaporator shell is insulated with NBR (Nitrile-Butadiene Rubber) of 3/4"(19mm) thickness and black color.

6. Control equipment

- 1) Controller operates overall system in optimal condition with a micro-computer unit installed in the chiller, and based on the 4 measured values such as suction gas pressure, discharge gas pressure, discharge gas temperature, and heat exchanger refrigerant temperature, it shall be able to control electronic expansion valve and compressor(Inverter driven), etc.
- 2) There should be a function that can check all sensors connected to the chiller and various operation status.
- 3) It should be equipped with self-protection devices and system protection function.
- 4) Module type control interface shall be applied so that simple product control is possible in series installation, and relocation and re-installation of HMI controller shall be possible without shifting other control devices.

7. Refrigerant Piping

- 1) Refrigerant pipe shall be made of purity 99.9% or above Phosphorus Deoxidized Copper without joint, and it should be connected for fluent refrigerant flow between each component.
- 2) Check valve at compressor discharge side to prevent reverse flow of the discharged refrigerant shall be installed.
- 3) Strainer in the pipe to prevent solid bodies or particles from mixing in a liquid stream shall be installed.
- 4) The pipe from expansion valve to evaporator should be insulated to prevent moisture condensation on the surface of the pipe and to prevent flash gas generation from refrigerant fluid at the same time.

8. Safety devices

- 1) Refrigerant pressure(Normal refrigerant pressure)
 - A. High pressure switch
 - B. High voltage protection(Sensor)
- 2) Temperature
 - A. compressor discharge temperature superheating detection(Sensor)
 - B. IPM temperature detection(Sensor)
 - C. Chiller and burst protection(Sensor)
 - D. Power Module application(Sensor)
- 3) Chilled water flow
 - A. Chilled water flow switch
- 4) Voltage and current(Control logic)
 - A. Revere phase detection and protection (Voltage monitoring system)
 - B. Compressor over-current protection
 - C. Fan motor over-current protection

Guide Specification(ACHH Series)



Contents

1. Casing
2. Compressor
3. Condenser
4. Electronic expansion valve
5. Evaporator
6. Control equipment
7. Ref. piping
8. Safety devices



Guide specification



Manufacturing specification

- 1) Use parts and materials of KS standard or equivalent for chillers not specified in this specification, and all parts should be designed with structure that is easy for replacement, repair, and inspection.
- 2) If there is a problem in the chiller, or if there is an abnormal status of chilled water temperature and flow amount, etc., immediately stop the chiller operation and you have to be equipped with certified equipment or function that can easily be identified.
- 3) There should be a protection circuit to prevent chiller damage by blackout or frequent voltage variation from power plant.
- 4) Heat pump should be able to operate silently without abnormal noise or abnormal vibration.
- 5) Heat pump should be composed of the central controller and the circuit possible for wired/wireless Start/Stop operation.
- 6) Easy combination should be possible with compact and module type design.
- 7) It should be the structure possible for back-up operation even if compressor or some parts fail and cooling operation should be available during parts replacement, repair, or inspection.
- 8) The main power cable with equivalent or above the specification presented in the product specification of each corresponding model should be used for the chiller, each communication line and power cable should use cable pipe for protection, and the cable pipe with the material that can block external electrical noise according to the installation environment should be used.

Air cooled type scroll heat pump product specification

1. Casing
 - 1) It should have the structure that is easy for disassembly and assembly for easy maintenance/repair.
 - 2) It should have a good looking exterior and it should be insulated to prevent condensation.
 - 3) It should have the structure preventing vibration and abnormal noise.
 - 4) It should have the structure that can be grounded.
2. Compressor
 - 1) R410A refrigerant shall be used in compressor whose casing shall be completely sealed hermetic type. Combination of two inverter scroll compressors shall be provided which shall be adjusted for soft loading, and shall be a high efficiency compressing system that can optimize energy consumption by using inverter control.
 - 2) Vibration prevention rubber should be used to prevent transferring noise and vibration during operation.

- 3) The frequency variable boundary of inverter scroll compressor shall be minimum 30Hz and maximum 127Hz.
- 4) Alternating operation should be possible to have the uniform average operation time for each compressor.
- 5) If multi-compressor is installed at the product, machine should keep operating when any compressor is in malfunction or trouble. Compressor can be replaced after stopping operation of machine. At this time, abnormal condition of the compressor should be confirmed by user through system controller.

3. Air Side Heat Exchanger(Condenser)

- 1) Condenser heat exchanger shall be used with purity 99.9 % or above Phosphorus Deoxidized Copper without joint, and it shall have the structure with Al fin attached to increase the heating area.(Cross fin & Tube type)
- 2) Use wide louver fin for Al fin, and pipe extension shall be carried out for efficient heat transfer.
- 3) Condenser air cooled type heat exchanger arrangement shall be 3 rows, 48 levels of 14FPI.
- 4) Pressure test for high pressure part in refrigerant side should be carried out at 4.18 MPa or above(Designed pressure 3.8 MPa), and there should not be problems such as leakage or deformation.
- 5) Condensing coil that passed pressure test should be vacuumed to completely remove moisture inside.
- 6) Use propeller type Fans, which should be able to provide sufficient air flow required for cooling and heating. Also, it should have sufficient strength for rotating speed, and should be operated silently through balance test.
- 7) Motor should be BLDC type that can increase efficiency.
- 8) Fan shall be connected directly to driving motor.

4. Electronic Expansion Valve

- 1) It is used at adiabatic-expansion process in refrigeration cycle and expands high pressure fluid refrigerant at condenser exit converting to low temperature / low pressure state, and linear electronic expansion valve shall be activated to adjust refrigerant amount according to evaporator load during cooling operation.
- 2) Based on data from various sensors installed in the chiller, micro-computer shall be able to analyze operation status of the system and compressor shall control the optimum refrigerant amount linearly.
- 3) By applying electric pulse signal to stepping motor, it shall be able to play a role of adjusting refrigerant flow amount.

5. Water Side Heat Exchanger(Evaporator)

- 1) Evaporator shall be shell & tube type heat exchanger, and the material shall be carbon steel for shell and copper for tubes.
- 2) There should be no water leakage, and the durability should be guaranteed.

